

## MODEL KS SERIES UTILITY SHELF

### PARTS IDENTIFICATION

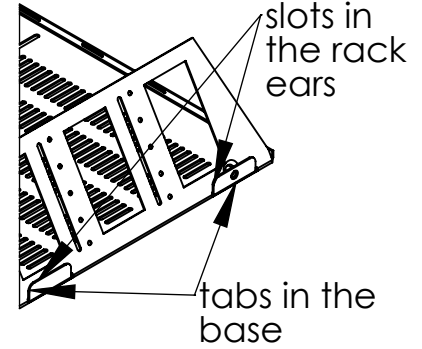
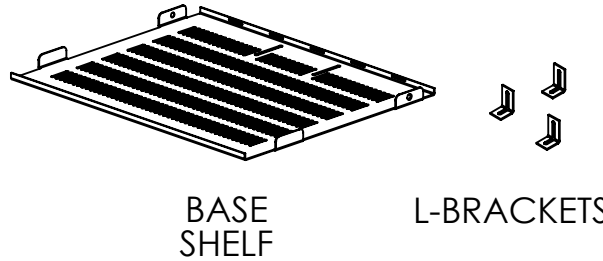
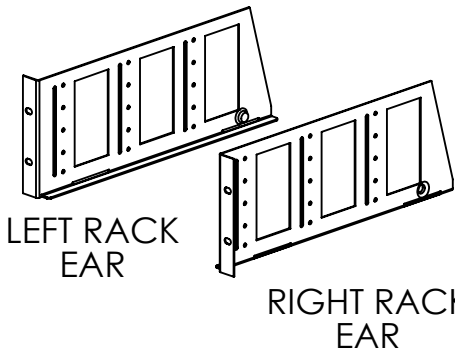

Position the right rack ear, left rack ear and base as shown. Slide the tabs in the base shelf through the slots in the rack ears.

Rotate the sides up as shown in the illustration and then slide each rack ear forward until the front flange of the sides are even with the front flange of the horizontal shelf.

Align the countersunk holes in the rear of the horizontal shelf with the matching threaded holes in the rack ears. Insert a 10-32 x 1/4" flat head screw in each hole (qty:2).

L-brackets are supplied to help position the equipment on the shelf assembly (qty:3). Attach the L-brackets to the shelf assembly to suit with 6-32 truss head screws (qty:3) and 6-32 keps nuts (qty:3)

Mount the shelf assembly on the cabinet front mounting rails with 10-32 x 7/8" screws (qty:4).

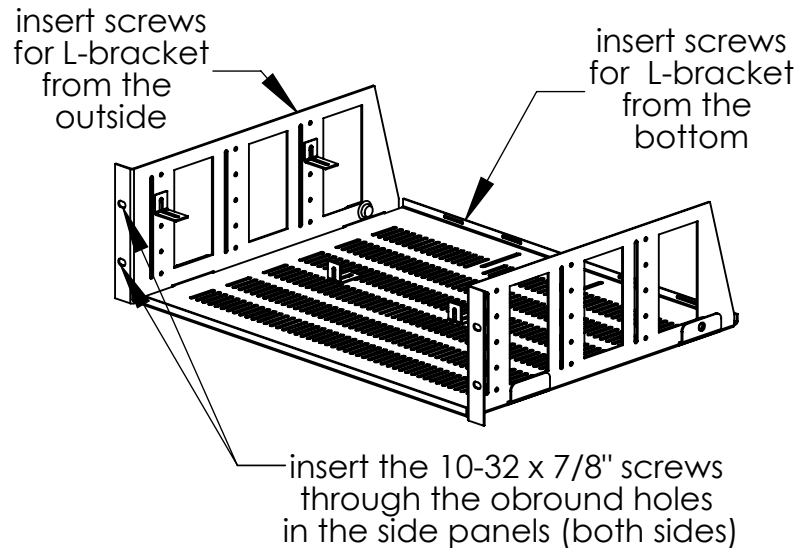
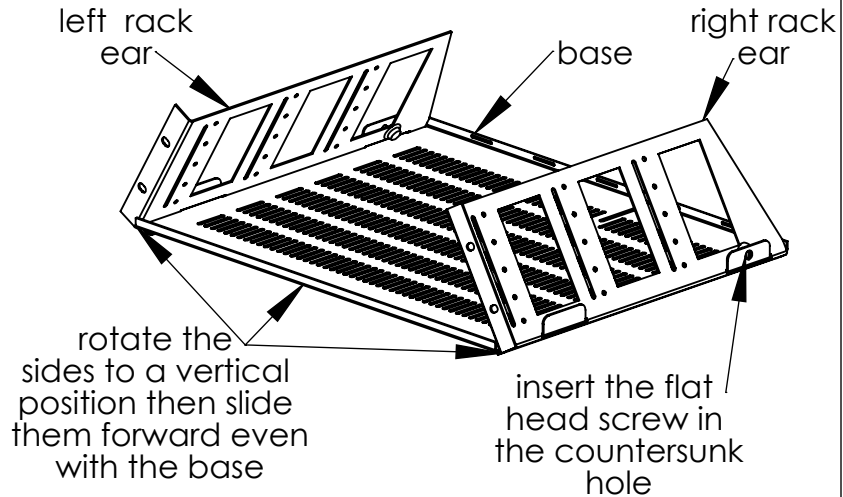

#### HARDWARE:

- 4 10-32 X 7/8" FINISH HD SCREWS (P/N: 10569)
- 2 10-32 X 1/4" FHMS (UC) (P/N: 19455)
- 3 6-32 X 5/16" PHMS (P/N: 4340)
- 3 6-32 KEPS NUTS (P/N: 7876)
- 3 L-BRACKETS (P/N: 19141)

**P/N: 19507**