

Series No.

FS Series

Flat-Ship, Wall-Mount Shelf

Overall Height: 8.24" [209]

Overall Depth: 14.00" [356], 16.00" [406], or 20.00" [508]

Overall Width: 18.22" [463]

Load Capacity: 100 lbs. [45 kg]



Mounts in either direction
on 16" centers

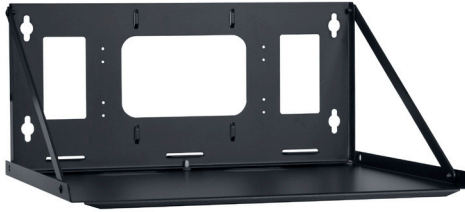

Innovative wall-mount shelf design ships completely assembled for cost-effective installation, yet ships flat in a compact carton for economical shipping and convenient warehousing.

FEATURES

CONSTRUCTION:

- USA-certified steel, 16-gauge
- Smooth-black powder-coat finish
- Front retaining lip, flanged for strength

CABLE MANAGEMENT:

- Oblong cutouts (2.5" x 1.25") in equipment platform allow cable drop-down
- Rear bridge lances for wire management

INSTALLATION:

- Rotate rear panel 90 degrees until flanges on front panel can be inserted into cutouts in the rear panel.
- Keyhole slots on 16" centers are slotted, allowing shelf to be installed with equipment platform on top or bottom
- Large central opening in back allows versatile wire access and placement over existing outlets or fixtures.
- Smaller openings in back are spaced to allow for single gang, stud-mounted conduit boxes.
- Pre-punched holes in back allow easy installation of surface-mounted gang-size accessories.

A&E SPECIFICATIONS

The wall-mount shelf shall be Lowell Model FS18-____, with overall dimensions of 18.22"W x ____"D x 8.24"H. Construction shall be 16-gauge steel. The shelf shall feature a hinge so it ships flat, unfolds to the service position, and supports up to 100 lbs. when properly mounted (with equipment platform on top or bottom) with keyhole mounting slots on 16" centers. The rear shall have a large center opening to accommodate an existing wall fixture, plus openings spaced to accommodate single-gang stud-mounted conduit boxes. The rear of the shelf shall be pre-punched for mounting accessories, and include bridge lances for cable management. The equipment platform shall have a retaining lip with flange, and two oblong cutouts (2.5" x 1.25") for cable drop-down. The shelf shall be manufactured in the USA using USA-certified steel and have a smooth-black powder-coat finish. It shall be Trade Agreement Act (TAA) compliant and Buy American Act (BAA) compliant.



TECHNICAL DRAWINGS

Dimensions are inches and [mm] unless stated otherwise.

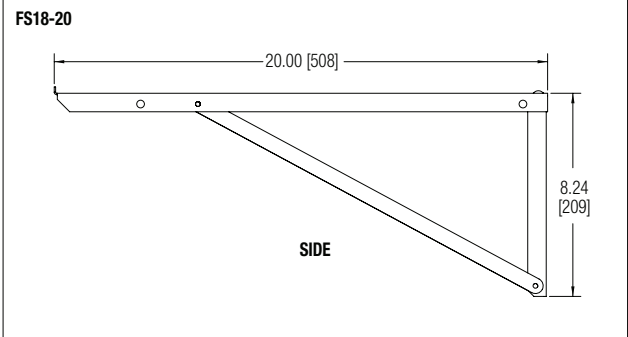
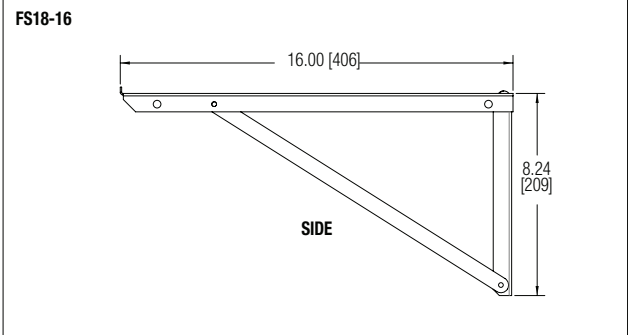
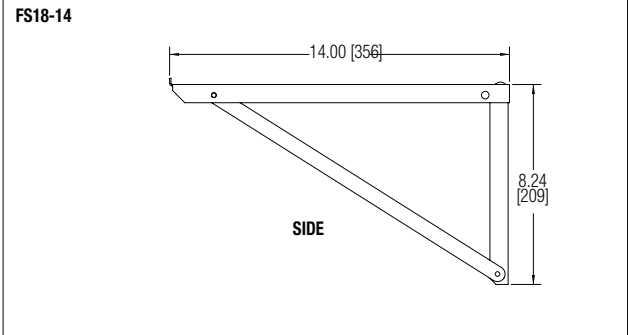
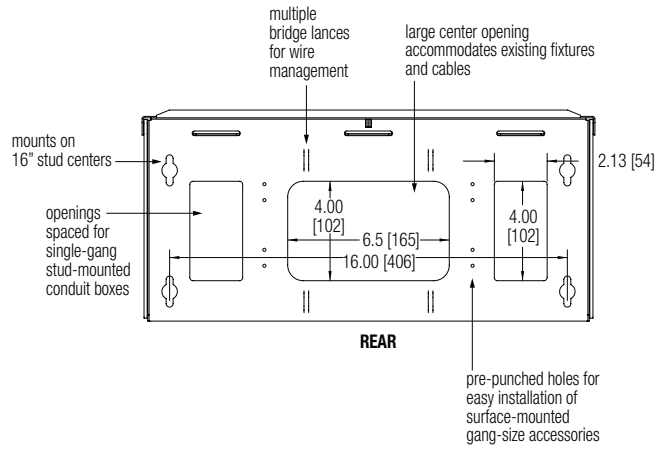
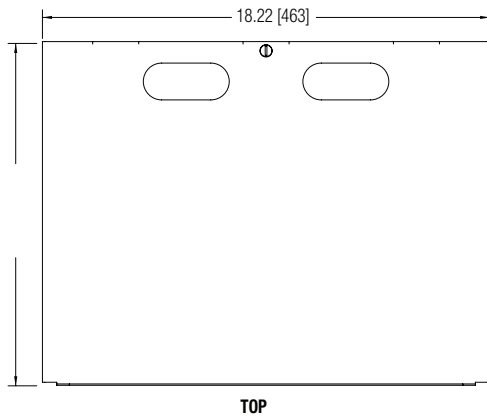

General Anchor Reference for FS Series Shelves

All fasteners & anchoring methods specified by site engineer/inspector as required.

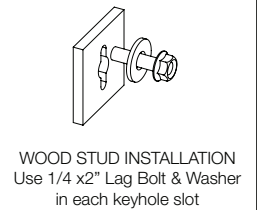
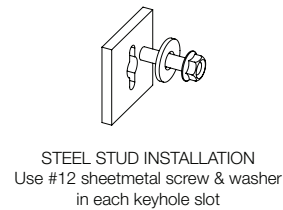
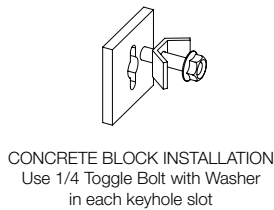
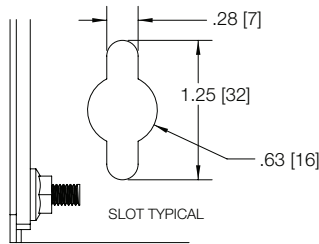

SERIES SUMMARY

Model No.	Overall Height	Overall Width	Overall Depth	Load Capacity
FS18-14	8.24 [209]	18.22 [463]	14.00 [356]	100 lbs. [45 kg]
FS18-16	8.24 [209]	18.22 [463]	16.00 [406]	100 lbs. [45 kg]
FS18-20	8.24 [209]	18.22 [463]	20.00 [508]	100 lbs. [45 kg]

Rounded dimensions inches and [mm]; 1U = 1.75"