



LXR-3021 shown. Side support brackets are included with 30U model only.

LXR Series

Slim AV Rack

Overall Width:	19.21 inches [586 mm]
Panel Space:	8U, 14U, 22U, or 30U
Overall Height:	17.84" [453 mm], 28.34" [720 mm], 42.34" [1075 mm], or 56.34" [1431 mm]
Overall Depth:	21.00 inches [533 mm]
Load Capacity:	400 lbs. [181 kg]
Finish:	Smooth-black powder-coat finish



SLIM OPEN FRAME RACK for 19 inch equipment is made to fit where a standard rack may not, such as inside millwork or under a counter. Ships unassembled.

FEATURES

CONSTRUCTION: 14-gauge USA-certified steel frame. Smooth-black powder-coat finish. Ships unassembled.

TOP: Steel top has vents on front and top, and combination knockouts in the rear (1/2–3/4 in.).

BASE: Steel base has front vents and a large (10.5 in. x 9 in.) opening in the bottom. It also features combination knockouts in the rear (1/2–3/4 in.).

CORNER-POST RAILS: 11-gauge steel corner-post rails are tapped 10-32 and printed with bi-directional RU increments (rails can be installed in either direction).

SIDES: Open sides feature obrounds in top and base for easy cable management. 30U racks include a pair of side support brackets to aid stability.

HARDWARE: Assembly and panel mounting hardware (hex nuts, flat head screws). Includes 3/8" – 16 threaded T-nuts for optional leg levelers.

COMPLIANCE/CERTIFICATION:

- EIA/TIA compliant
- TAA compliant
- BAA compliant
- USA-certified steel
- Made in USA

ACCESSORIES: (order separately)

- LL: Set of 4 leg levelers
- PRK: Protective runner kit for slide-in applications
- ISO-LL: Set of 4 electrical isolation leg levelers
- ISO-P1: Rack isolation pads for concrete floors
- LXR-C3SL: Set of 4 swivel casters (two locking)
- LXR-C3SFL: Set of 4 swivel casters with special tread to help protect fine floors (two locking)

A&E SPECIFICATIONS

The EIA/TIA compliant 19" equipment rack shall be Lowell model LXR-_____ with overall dimensions of _____"H x 21"D x 19.21"W and usable height of ____ rack units. Construction shall be steel with 14-gauge frame, 11-gauge corner-post rails tapped 10-32, and side support brackets (for 30U rack only). It shall feature combination knockouts (1/2–3/4") in the rear and side obrounds in top and base for cable management. The bottom opening shall measure 10.50" x 9.00". The rack shall be manufactured in the USA using USA-certified steel and have a smooth-black powder-coat finish. It shall be Trade Agreements Act (TAA) compliant and Buy American Act (BAA) compliant. The rack ships unassembled.

TECHNICAL DRAWINGS

Dimensions: inches [mm] unless stated otherwise.

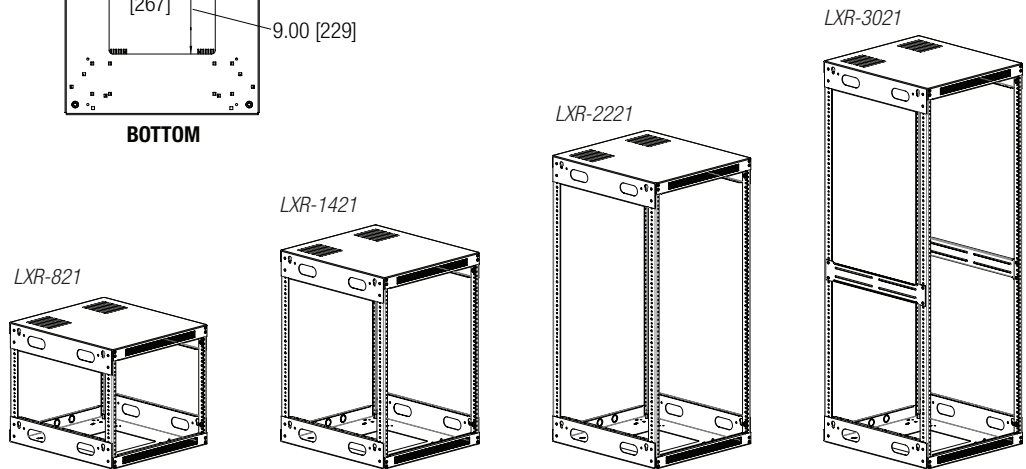
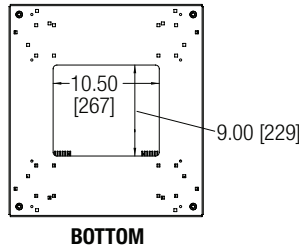
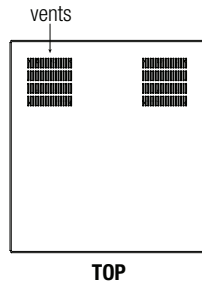
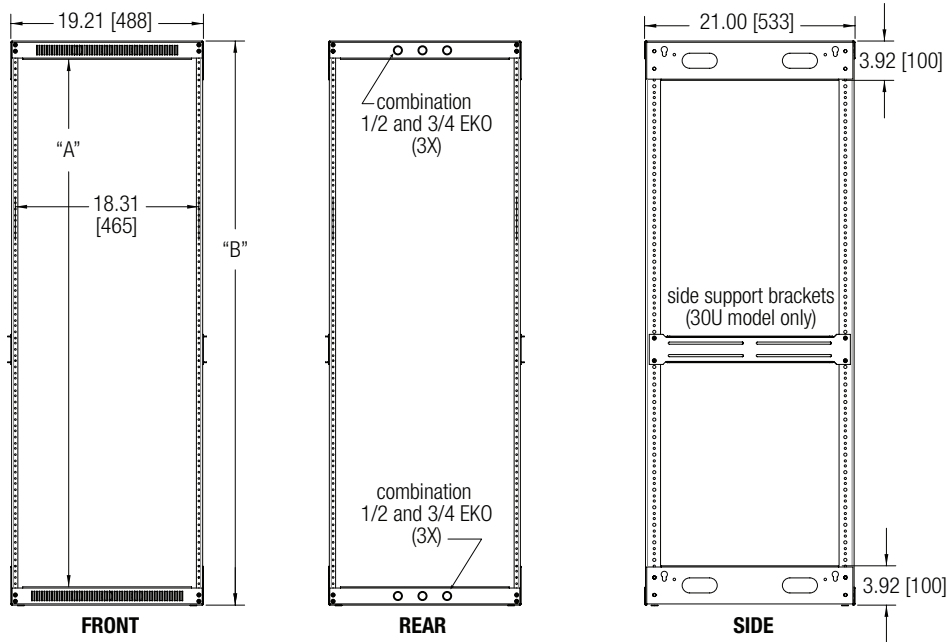

LXR SERIES SUMMARY

Model No.	"A" Rack Units	Overall Depth inches [mm]	"B" Overall Height inches [mm]	Usable Height inches [mm]	Overall Width inches [mm]	Bottom Opening inches [mm]	Bottom Support Rails	Side Support Brackets
LXR-821	8U	21.00 [533]	17.84 [453]	14.00 [356]	19.21 [488]	9 x 10.5 [229 x 267]	4	----
LXR-1421	14U	21.00 [533]	28.34 [720]	24.50 [622]	19.21 [488]	9 x 10.5 [229 x 267]	4	----
LXR-2221	22U	21.00 [533]	42.34 [1075]	38.50 [978]	19.21 [488]	9 x 10.5 [229 x 267]	4	----
LXR-3021	30U	21.00 [533]	56.34 [1431]	52.50 [1334]	19.21 [488]	9 x 10.5 [229 x 267]	4	2

1U = 1.75"

OPTIONAL ACCESSORIES: Order Separately



LL: Set of 4 leg levels

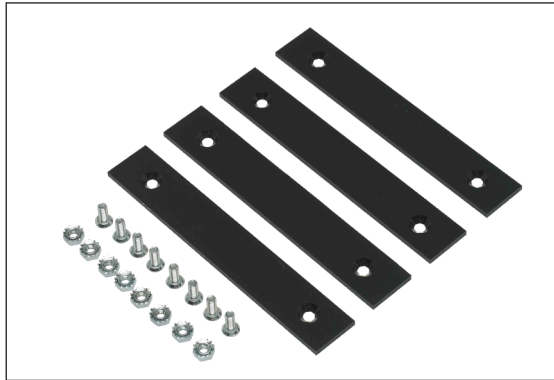

PRK: Protective runner kit for slide-in applications



ISO-LL: Set of 4 electrical isolation leg levels

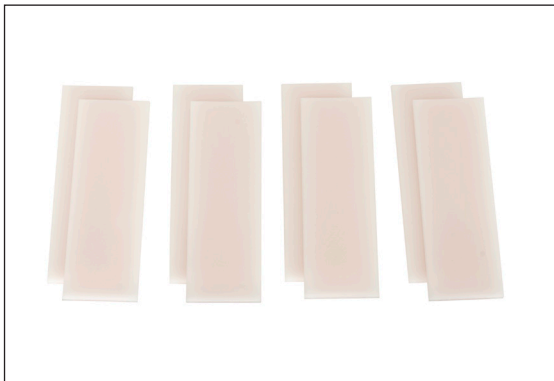

ISO-P1: Rack isolation pads for concrete floors



LXR-C3SL: Set of 4 swivel casters (two locking)

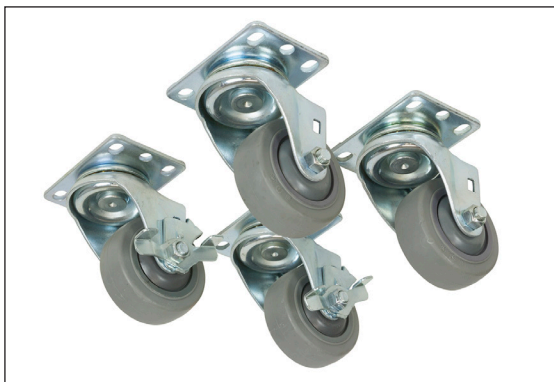

LXR-C3SFL: Set of 4 swivel casters with special tread to help protect fine floors (two locking)