



Sample installation.
Clock is not included with grille.



Series

DC802

Grille for Digital Clock/Speaker Center

The DC802 grille series provides a simple solution for installing an 8" paging speaker and digital clock in a single unit. The compact dual-function design provides a small architectural footprint, reducing fixture and labor costs—ideal for classrooms, sports complexes, medical and professional buildings

Note: Order backbox, speaker, and clock separately.

FEATURES:

CONSTRUCTION: Grille is formed from single piece of 18-gauge USA-certified steel with white powder-coat finish.

DIMENSIONS: 12.688" square

CUTOUT: Sized for a digital clock face (see chart below)

MOUNTING AIDS:

- Welded studs to mount a standard 8" speaker
- White screws

COUNTRY OF ORIGIN: Made in USA

COMPLIANCE: TAA and BAA compliant

COMPATIBLE COMPONENTS (order separately):

SPEAKER: 810

RECESSED ENCLOSURE: RE1175

SURFACE-MOUNT ENCLOSURE: SE1275

DIGITAL CLOCK: Source from clock supplier.

A&E SPECIFICATIONS:

The grille for the digital clock/speaker center shall be Lowell model _____, which shall be formed from 18-gauge steel and given a white powder-coat finish. The grille shall measure 12.688" square. It shall feature a rectangular perforation area, welded studs to mount a standard 8" speaker, and a cutout to mount the specified digital clock. The grille shall be manufactured in the USA using USA-certified steel, and it shall be Trade Agreement Act (TAA) compliant and Buy American Act (BAA) compliant. Speaker, clock, and backbox shall be ordered separately.

COMPATIBILITY CHART

Grille Model	Digital Clock *	Surface Backbox**	Recessed Backbox**	Speaker***
DC802-DD3	Dukane 24D20	SE1275	RE1175	810
	Dukane 24D20A	SE1275	RE1175	810
DC802-DF	Faraday 2363-24	SE1275	RE1175	810
DC802-SAP1	Sapling SBD 2.5" 4 digits	SE1275	RE1175	810
	Sapling SBP 2.5" 4 digits	SE1275	RE1175	810

* Order clock from clock manufacturer or distributor.

** Open backbox (not divided). If a 110V clock is used the installer will need to isolate the clock to meet local code.

*** Fits standard 8" EIA speaker. Lowell offers many models, including some with a mounted transformer.

DC802-DD3

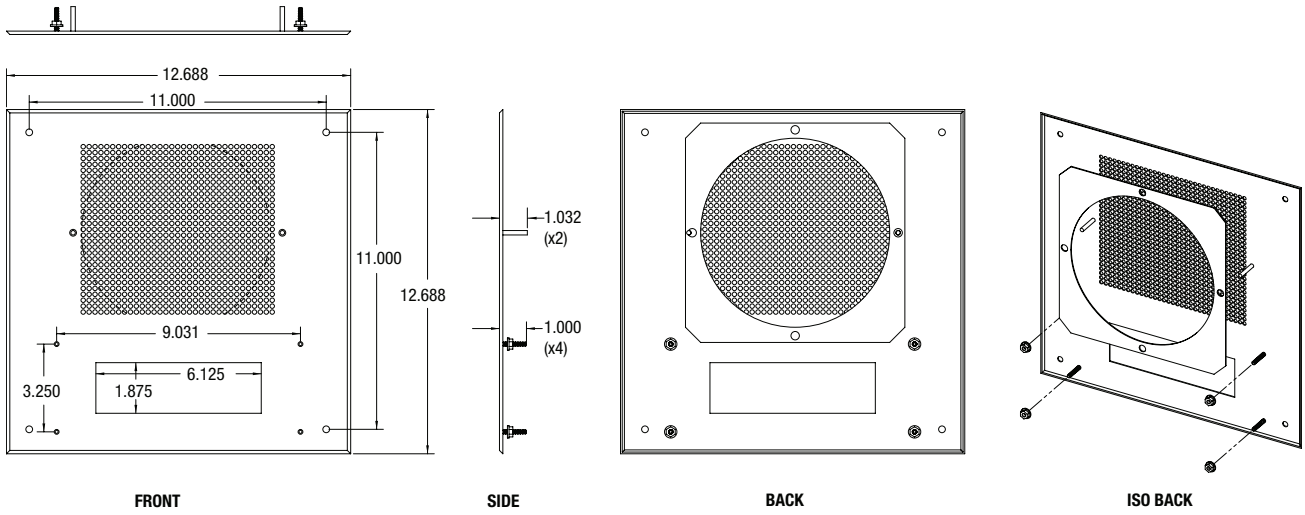

DC802-DF

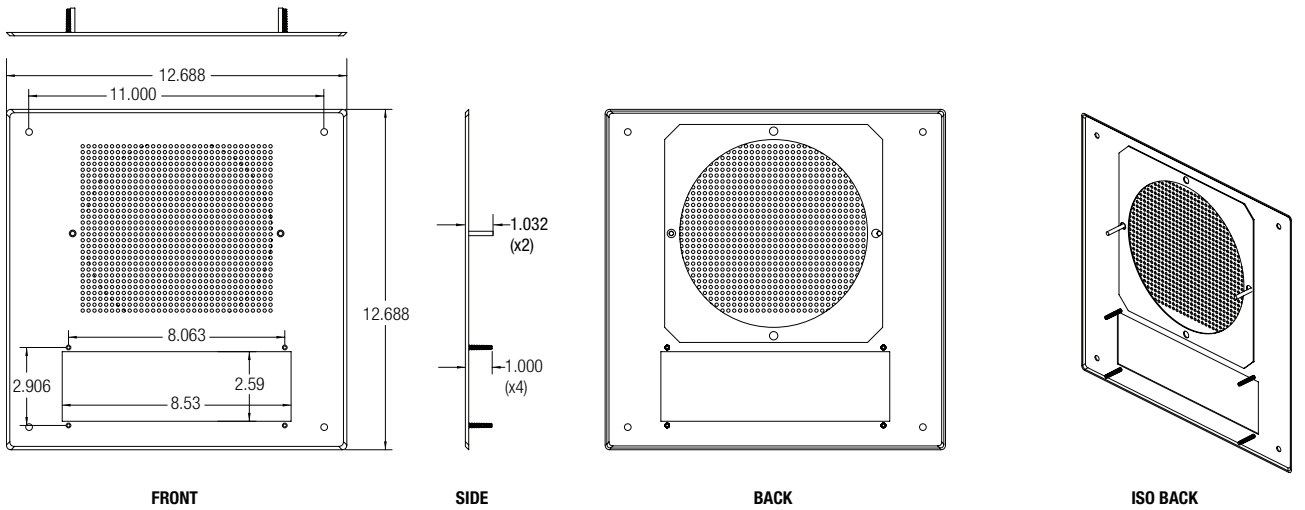

DC802-SAP1

