



# LGR Series



## 19" Gangable Rack – Fully Welded, Open-Frame

- Panel Space: 24, 35, 40, and 44U
- Overall Depth: 42" [1067], 36" [914], 32" [813], 27" [686], and 22" [559]
- Overall Width: 23.06" [586]
- Load Capacity: 3150 lbs. [1429 kg] — UL Listed

### FEATURES

**MATERIAL:** Fully-welded USA- certified steel 16-gauge frame with seamless side frame construction and 14-gauge bottom reinforced at load-bearing junctions for robust support, strength equivalent to 11-ga. steel. Beveled edge corners front and rear.

**FINISH:** Black-textured powder-coat finish.

**FRONT:** Upper and lower vents. Frame nutserts are ready to add optional surface-mount door (left or right swing).

**REAR:** Knockout panels in frame above and below door with combination EKO's for conduit (1/2"–3/4" and 1"–1-1/2") and KO's for wireless antennae (1/2") above door. Includes recessed rear door with vents and key lock (left or right swing).

**SIDES:** Open with rear vertical array of 2" dia. holes plus 4" x 1.5" obround openings along base for cabling between racks. Optional side panels extend .625".

**BOTTOM:** Open, includes 10-32 threaded grounding stud in corner, 3/8"-16 threaded T-nuts for (optional) leg levelers, and holes for anchor bolts (by others).

**CONFIGURABLE TOP:** Features 12U opening with riveted 10-32 threaded rails on 19" EIA spacing (model dependent, see series summary chart).

**CABLE MANAGEMENT:** Abundant cable lacing points and generous wire management space of nearly 2" between front rails and front-to-rear rail supports.

**RACK RAILS (fully adjustable):** 11-gauge steel 10-32 threaded rails on EIA spacing with bi-directional numbered RU increments (rails mount in either direction). Smooth-black finish. Clearance from front rail to outside frame (1.75"), from front rail to optional surface-mount front door (2.5").

**HARDWARE:** Black pilot point screws with captive washers for quick installation. (50)

**COMPLIANCE:** EIA/TIA Compliant; UL 2416 Listed in US and Canada; TAA Compliant; BAA Compliant

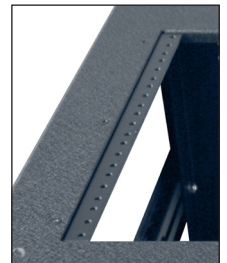

Threaded rails included in open top LER models.



Fully-adjustable front rails with printed RU increments.



Rear vertical array with 2" dia. holes and obrounds along base for cabling.

## OPTIONAL ACCESSORIES — LGR SERIES

- Surface-mount front door with key lock: LFD Series (solid steel), LFD--FV Series (fully-vented), or LFD--P Series (plexiglass)
- Recessed rear door with key lock: LRD-44FV (fully-vented),.
- Rack top kits: RTB Series (features cable brush panel), RTK series (features cable knockout panel)
- Side panels: SDP Series (solid steel)
- Mobile bases: LMB Series
- Additional pair of mounting rails: RRD Series
- Leg levelers: LL (set of 4)
- Plastic bushings: LGRB-12 (12 pk)

## A&E SPECIFICATIONS — LGR SERIES

The EIA/TIA-compliant 19" gangable equipment rack shall be Lowell model LGR-\_\_\_\_\_ with overall dimensions of \_\_\_\_\_"H x \_\_\_\_\_"D x 23.06"W; usable height of \_\_\_\_ rack units, and usable depth of \_\_\_\_\_". Rack construction shall be fully-welded USA-certified steel with 16-gauge frame and 14-gauge bottom reinforced at load-bearing junctions, all with black-textured powder-coat finish. Open sides shall feature rear vertical arrays of 2" dia. holes plus 4" x 1.5" obround openings along bottom. The rack shall include a recessed rear door with vents and key lock, knockout panels above and below door with 1/2"-3/4" and 1"-1-1/2" EKO for conduit, and 1/2" KO for wireless antennae above door. The front shall feature vents along top and bottom, and provisions to accept an (optional) surface-mount door with left or right hand swing. The top shall feature a 12U opening with riveted 10-32 threaded rails on 19" EIA spacing, and 1/2" KO for wireless antennae. Rack bottom shall have an opening measuring \_\_\_\_\_"D x 19.94"W and include a grounding stud. Rack shall include (\_\_\_\_U) adjustable 11-gauge steel rails tapped 10-32 on 19" EIA spacing with smooth-black finish and numbered rack unit increments. The UL2416-Listed rack shall be manufactured in the USA with a UL-Listed load capacity of 3150 lbs., and shall be Trade Agreement Act (TAA) and Buy American Act (BAA) compliant. Use chart to fill in blank information.

## LGR SERIES SUMMARY

Model No.	Units	"A" Overall Depth	"B" Usable Depth	"B" Overall Height	"C" Usable Height	"D" Overall Width	Top Opening	"E" - Bottom Opening Depth	"F" - Bottom Opening Width	Adj. Rails	UL Load Capacity	UL Listed
LGR-2427	24 U	27.00 [686]	24.34 [618]	48.13 [1222]	42.13 [1070]	23.06 [586]	12 U	22.88 [581]	19.94 [506]	2 pr	3150	Yes
LGR-3527	35 U	27.00 [686]	24.34 [618]	67.38 [1711]	61.38 [1559]	23.06 [586]	12 U	22.88 [581]	19.94 [506]	2 pr	3150	Yes
LGR-4027	40 U	27.00 [686]	24.34 [618]	76.13 [1934]	70.13 [1781]	23.06 [586]	12 U	22.88 [581]	19.94 [506]	2 pr	3150	Yes
LGR-4427 *	44 U	27.00 [686]	24.34 [618]	83.13 [2111]	77.13 [1959]	23.06 [586]	12 U	22.88 [581]	19.94 [506]	2 pr	3150	Yes
LGR-3532	35 U	32.00 [813]	29.34 [745]	67.38 [1711]	61.38 [1559]	23.06 [586]	12 U	27.88 [708]	19.94 [506]	2 pr	3150	Yes
LGR-4032	40 U	32.00 [813]	29.34 [745]	76.13 [1934]	70.13 [1781]	23.06 [586]	12 U	27.88 [708]	19.94 [506]	2 pr	3150	Yes
LGR-4432 * ◊	44 U	32.00 [813]	29.34 [745]	83.13 [2111]	77.13 [1959]	23.06 [586]	12 U	27.88 [708]	19.94 [506]	2 pr	3150	Yes
LGR-4036	40 U	36.00 [914]	33.34 [847]	76.13 [1934]	70.13 [1781]	23.06 [586]	12 U	31.88 [810]	19.94 [506]	2 pr	3150	Yes
LGR-4436 * ◊	44 U	36.00 [914]	33.34 [847]	83.13 [2111]	77.13 [1959]	23.06 [586]	12 U	31.88 [810]	19.94 [506]	2 pr	3150	Yes
LGR-4042	40 U	42.00 [1067]	39.34 [999]	76.13 [1934]	70.13 [1781]	23.06 [586]	12 U	37.88 [962]	19.94 [506]	2 pr	3150	Yes
LGR-4442 *	44 U	42.00 [1067]	39.34 [999]	83.13 [2111]	77.13 [1959]	23.06 [586]	12 U	37.88 [962]	19.94 [506]	2 pr	3150	Yes

Rack dimensions (rounded) – inches and [mm]; 1U = 1.75"; \* Available without rear door, add "-LRD" suffix to model number (ex. LGR-4427-LRD); ◊ seismic-certified (LSGR series) racks available, see pg. 3



# LSGR Series

## 19" Gangable Rack – Seismic Certified, Fully Welded

Panel Space:	44U
Overall Depth:	32" [813], and 36" [914]
Overall Width:	23.06" [586]
Load Capacity:	3150 lbs. [1429 kg] – UL Listed
Seismic Load Capacity:	Ip = 1.0 : 1200 lbs.; Ip = 1.5 : 900 lbs.

### FEATURES

**CONSTRUCTION:** Fully-welded USA-certified steel 16-gauge frame with 14-ga. bottom reinforced at load-bearing junctions for robust support, strength equivalent to 11-ga. steel. Black-textured powder-coat finish. Beveled edge corners front and rear.

**FRONT:** Upper and lower vents. Frame nutserts are ready to add optional surface-mount door (left or right swing).

**REAR:** Two knockout panels in frame above and below door with combination EKO for conduit (1/2"–3/4" and 1"–1-1/2") and KO for wireless antennae (1/2"). Includes recessed door with vents and key lock (left or right swing).

**SIDES:** Open with seamless X-frame construction with multiple openings for cable runs between racks. Rear vertical array of 2" dia. holes plus 4" x 1.5" obround openings along base. Optional side panels (order separately).

**BOTTOM:** Open with welded bracket in each corner with hole for anchor bolt (by others). 10-32 threaded grounding stud.

**CONFIGURABLE TOP:** 12U opening with riveted 10-32 threaded rails on 19" EIA spacing.

**CABLE MANAGEMENT:** Combination knockouts in top and rear. Abundant cable lacing points and generous wire management space of nearly 2" between front rails and front-to-rear rail supports.

**RACK RAILS** (fully adjustable): 11-ga. steel 10-32 threaded rails on EIA spacing with bi-directional numbered RU increments (rails mount in either direction). Smooth-black finish. Clearance from front rail to outside frame (1.75"), from front rail to optional surface-mount door (2.5").

**HARDWARE:** Black pilot point screws with captive washers for quick installation. (50)

**COMPLIANCE:** EIA/TIA Compliant; UL 2416 Listed in US and Canada; TAA Compliant; BAA Compliant. Ships with PE Certified documentation.

**SEISMIC CERTIFICATION:** Professional Engineer (PE) certified\* to meet or exceed requirements for Category 1 (Ip = 1.5, Life Safety/Essential System) and Category 2 (Ip = 1.0, NOT identified as a Life Safety/Essential System) as specified in:

- International Building Code: IBC 2009, Sect. 1613
- California Building Code: CBC 2010, Sect. 1613
- California Office of Statewide Health Planning and Development: OSHPD 2010

\*Seismic certified when anchored in accordance with IBC/CBC/OSHPD seismic summary and installation manuals available for download at Lowellmfg.com.

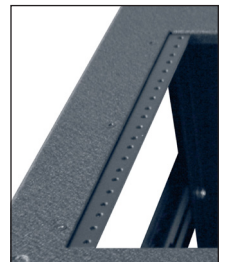

Threaded rails included in open top LSER models.

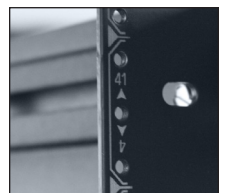

Fully-adjustable front rails with printed RU increments.

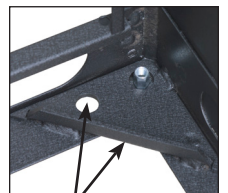

Welded bracket, and anchor holes in seismic rack base.

## OPTIONAL ACCESSORIES – LSGR SERIES

- Surface-mount front door with key lock: LFD-44 (solid steel), LFD-44FV (fully-vented), or LFD-44P (plexiglass)
- Recessed rear door with key lock: LRD-44FV (fully-vented)
- Rack top kits: RTB Series (features cable brush panel), RTK series (features cable knockout panel)
- Side panels: SDP Series (solid steel)
- Additional pair of mounting rails: RRD-44
- Plastic bushings: LGRB-12 (12 pk)

**NOTE: Seismic racks and cabinets will not accept a mobile or stationary base.**

## A&E SPECIFICATIONS – LSGR SERIES

The EIA/TIA-compliant 19" floor rack shall be Lowell model LSGR-\_\_\_\_\_ with overall dimensions of 83.13"H x \_\_\_\_\_"D x 23.06"W, usable height of 44 rack units, and usable depth of \_\_\_\_\_". Rack construction shall be fully-welded USA-certified steel with 16-gauge frame and 14-gauge bottom reinforced at load-bearing junctions, all with black-textured powder-coat finish. Open sides shall feature X-frame construction, rear vertical arrays of 2" dia. holes, and 4" x 1.5" obround openings along bottom. The rack shall include a recessed rear door with vents and key lock, two knockout panels above and below door with 1/2" KO for wireless antennae, 1/2"-3/4" and 1"-1-1/2" EKO for conduit. The front shall feature vents along top and bottom, and provisions to accept an (optional) surface-mount door with left or right hand swing. The top shall feature a 12U opening with riveted 10-32 threaded rails on 19" EIA spacing and 1/2" KO for wireless antennae. The bottom shall have an opening measuring \_\_\_\_\_" x 19.94", corner weldments, and a grounding stud. The rack shall include (44U) adjustable 11-gauge steel rails tapped 10-32 on 19" EIA spacing with smooth-black finish and numbered rack unit increments. The UL2416-Listed rack shall be manufactured in the USA with a UL-Listed load capacity of 3150 lbs, and shall be Trade Agreement Act (TAA) and Buy American Act (BAA) compliant.

The rack shall be PE certified\* to meet or exceed requirements for Category 1 (Ip=1.5, Life Safety/Essential System) and Category 2 (Ip=1.0, NOT identified as a Life Safety/Essential System) as specified in IBC 2009 Sect. 1613, CBC 2010 Sect. 1613, and OSHPD 2010, with seismic-certified load capacity of 1200 lbs. (Ip=1.0) and 900 lbs. (Ip =1.5).

*\*Seismic certified when anchored in accordance with IBC/CBC/OSHPD seismic summary and installation manuals available for download at Lowellmfg.com.*

## LSGR SERIES SUMMARY

Model No.	Units	"A" Overall Depth	Usable Depth	"B" Overall Height	"C" Usable Height	"D" Overall Width	Top Opening	"E" - Bottom Opening Depth	"F" - Bottom Opening Width	Adj. Rails	Seismic Load Cap.*	UL Listed Capacity	UL Listed
LSGR-4432	44 U	32.00 [813]	29.34 [745]	83.13 [2111]	77.13 [1959]	23.06 [586]	12 U	27.88 [708]	19.94 [506]	2 pr	900-1200	3150	Yes
LSGR-4436	44 U	36.00 [914]	33.34 [847]	83.13 [2111]	77.13 [1959]	23.06 [586]	12 U	31.88 [810]	19.94 [506]	2 pr	900-1200	3150	Yes

*Rack dimensions (rounded) – inches and [mm]; 1U = 1.75"; \* Seismic certified load capacity, Ip = 1.0 : 1200 lbs.; Ip = 1.5 : 900 lbs.*

# TECHNICAL DRAWINGS

Dimensions are inches and [mm] unless stated otherwise.

### TOP VIEWS

- 12U Open Top Models**
- LGR-2427 LGR-4432 LSGR-4427
  - LGR-3527 LGR-4036 LSGR-4432
  - LGR-4027 LGR-4436 LSGR-4436
  - LGR-4427 LGR-4042
  - LGR-3532 LGR-4442
  - LGR-4032

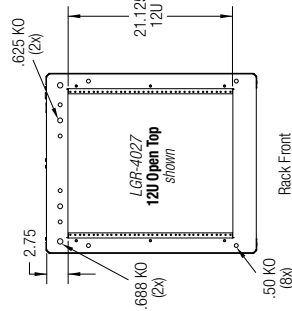

### LSGR SERIES

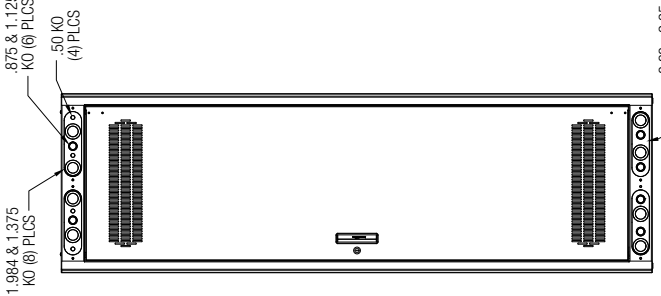
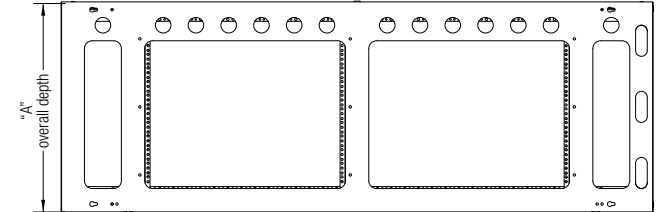
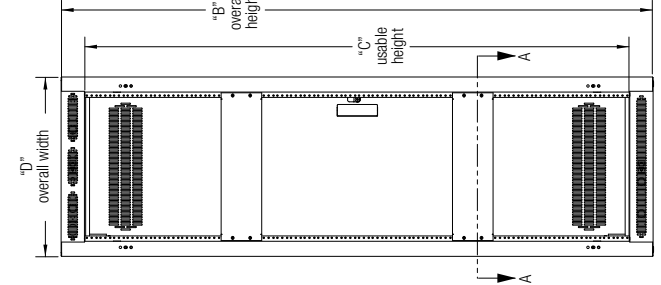
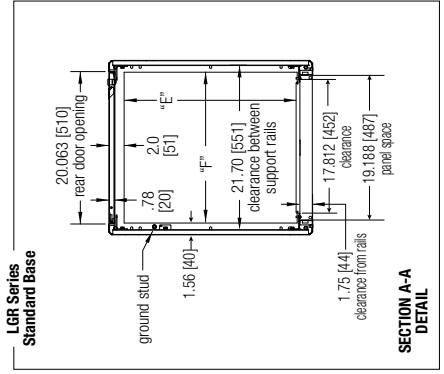
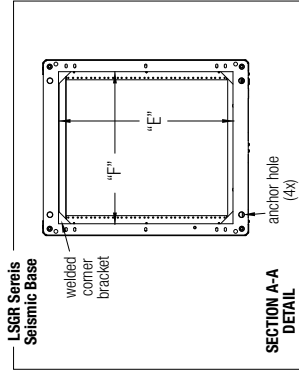
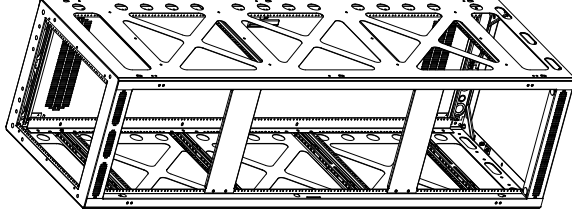
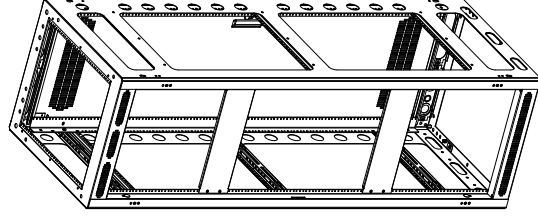

# SERIES SPECIFIC ACCESSORIES — SURFACE-MOUNT FRONT DOORS

Dimensions are inches and [mm] unless stated otherwise.

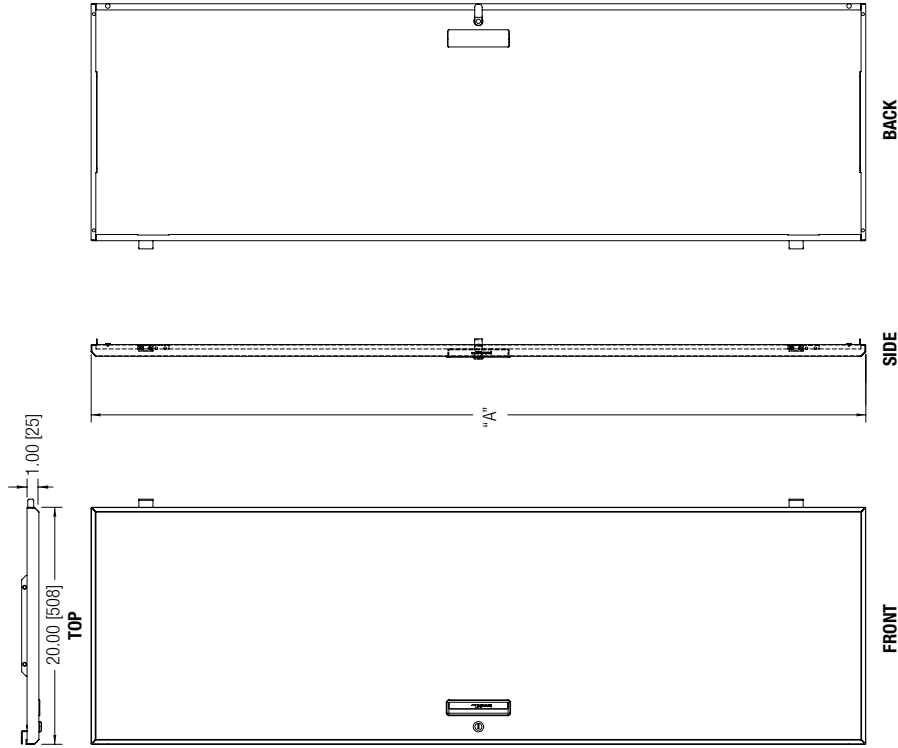

## STYLE OPTIONS for SURFACE-MOUNT FRONT DOOR

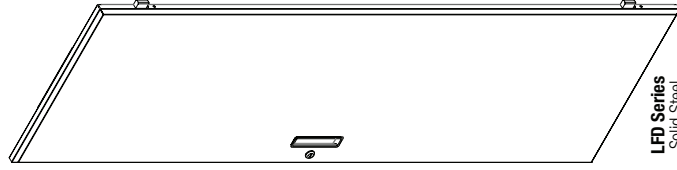

**LFD Series**  
Solid Steel

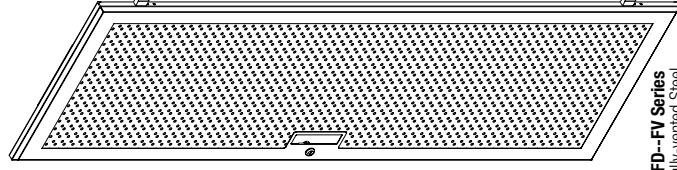

**LFD-FV Series**  
Fully-vented Steel

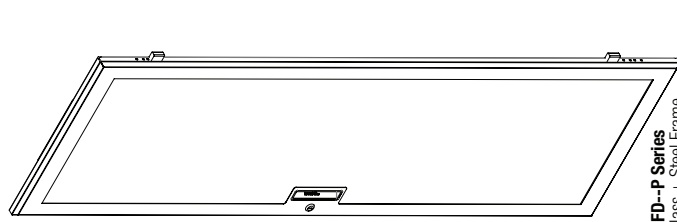

**LFD-P Series**  
Plexiglass + Steel Frame

### LFD Series Summary

Model No.	"A" = RU
LFD-7	7 U
LFD-10	10 U
LFD-12	12 U
LFD-14	14 U
LFD-16	16 U
LFD-18	18 U
LFD-21	21 U
LFD-24	24 U
LFD-35	35 U
LFD-40	40 U
LFD-44	44 U
LFD-54	54 U

### LFD-FV Series Summary

Model No.	"A" = RU
LFD-7FV	7 U
LFD-10FV	10 U
LFD-12FV	12 U
LFD-14FV	14 U
LFD-16FV	16 U
LFD-18FV	18 U
LFD-21FV	21 U
LFD-24FV	24 U
LFD-35FV	35 U
LFD-40FV	40 U
LFD-44FV	44 U

### LFD-P Series Summary

Model No.	"A" = RU
LFD-7P	7 U
LFD-10P	10 U
LFD-12P	12 U
LFD-14P	14 U
LFD-16P	16 U
LFD-18P	18 U
LFD-21P	21 U
LFD-24P	24 U
LFD-35P	35 U
LFD-40P	40 U
LFD-44P	44 U



# SERIES SPECIFIC ACCESSORIES — RECESSED REAR DOORS

Dimensions are inches and [mm] unless stated otherwise.

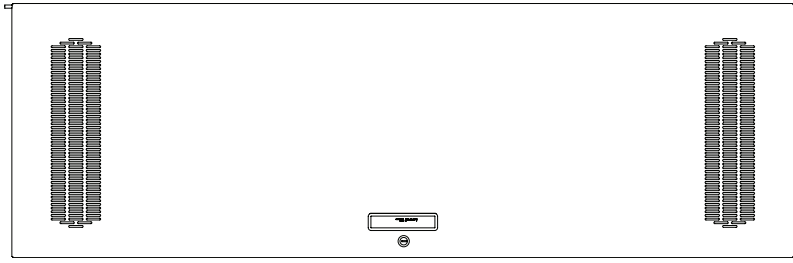
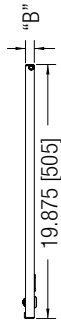

**Standard Rear Door**

"A" = RU  
 Rack Height  
 "B" = Depth  
 .688 [18]

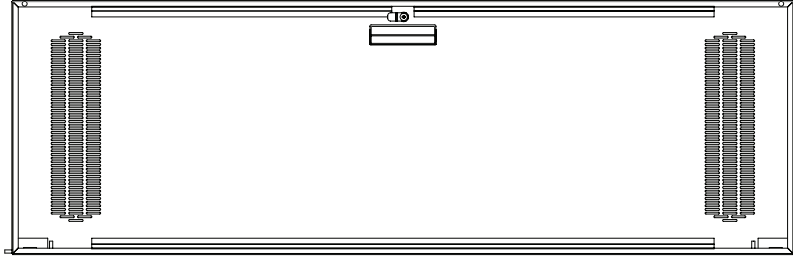
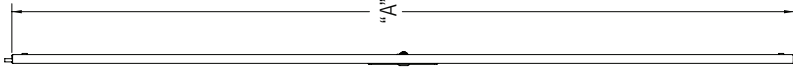

**Standard Rear Door**  
 Top/Bottom Vents  
 (recessed)

Standard rear door included  
 with most floor racks

**44U REPLACEMENT OPTION**

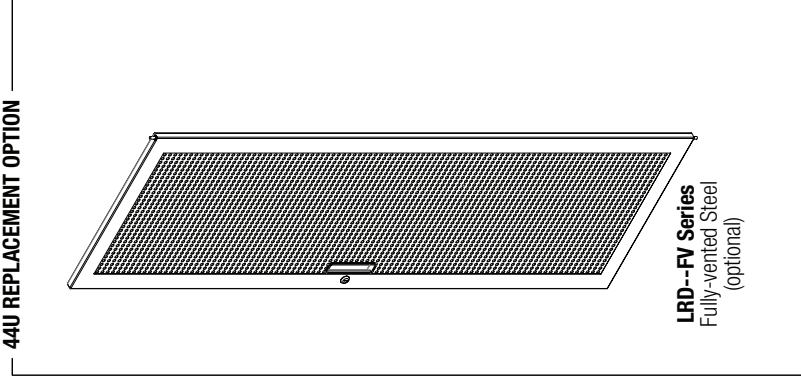

**LRD--FV Series**  
 Fully-vented Steel  
 (optional)

**LRD-44FV Summary**

Model No. "A" = RU "B" = Depth  
 ▶ LRD-44FV 44 U .688 [18]

▶ = accessory fits LGR / LSGR Series models



Lowell strives to provide accurate information while reserving the right to change specifications and/or improve manufacturing methods without prior notification.  
 ©2024 Lowell Manufacturing Co., 100 Integram Dr., Pacific, MO 63069, USA / tel. 800.325.9660 / tel. 636-257-3400 / www.lowellmfg.com

LGR / LSGR Series | Rev. 11-25-2025 | pg. 7/11

**Spec 2454**



# SERIES SPECIFIC ACCESSORIES — RACK TOP KITS

*Dimensions are inches and [mm] unless stated otherwise.*

**RTB Series**  
Rack tops with 3U cable brush panel and choice of 9U panel

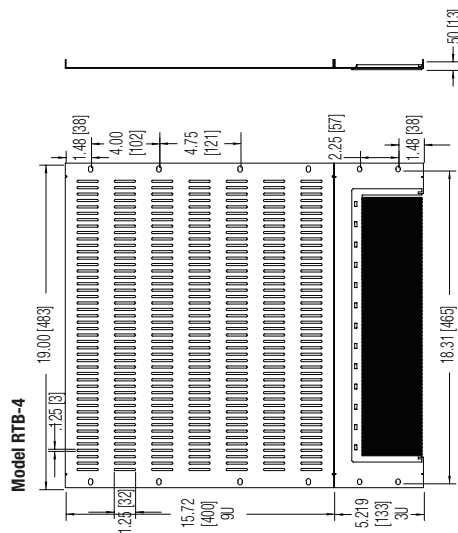
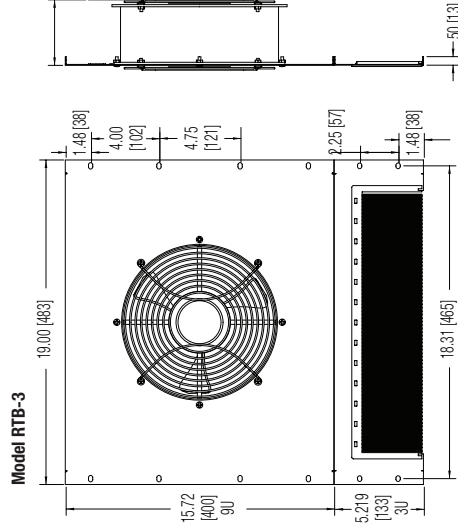
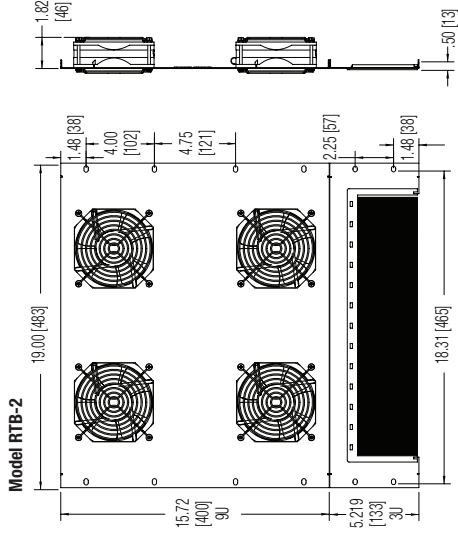
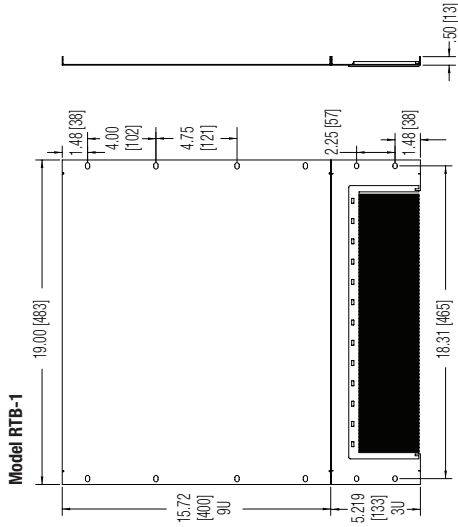

**RTB Series Summary**

Model No.	Description
▶ RTB-1	3U brush panel with 9U solid steel panel
▶ RTB-2	3U brush panel with 9U four fan panel
▶ RTB-3	3U brush panel with 9U turbo fan panel
▶ RTB-4	3U brush panel with 9U vented steel panel

▶ = accessory fits LGR / LSGR Series models

**RTK Series**  
Rack tops with 3U cable knockout panel and choice of 9U panel

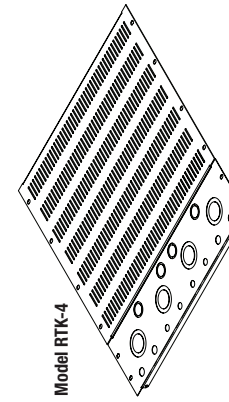
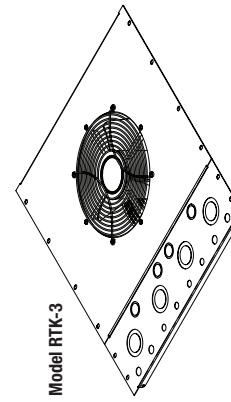
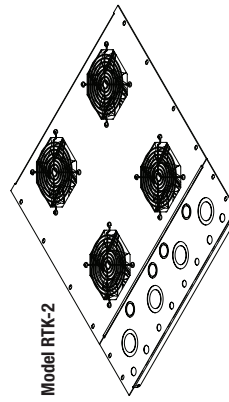
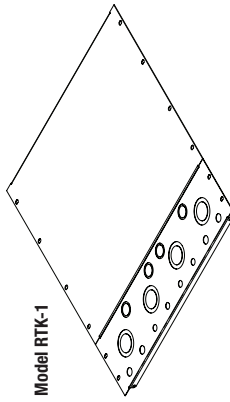

**RTK Series Summary**

Model No.	Description
▶ RTK-1	3U knockout panel with 9U solid steel panel
▶ RTK-2	3U knockout panel with 9U four fan panel
▶ RTK-3	3U knockout panel with 9U turbo fan panel
▶ RTK-4	3U knockout panel with 9U vented steel panel



# SERIES SPECIFIC ACCESSORIES — RECESSED REAR DOORS

Dimensions are inches and [mm] unless stated otherwise.

### SPLIT SIDE PANEL (2 PIECES PER SIDE)

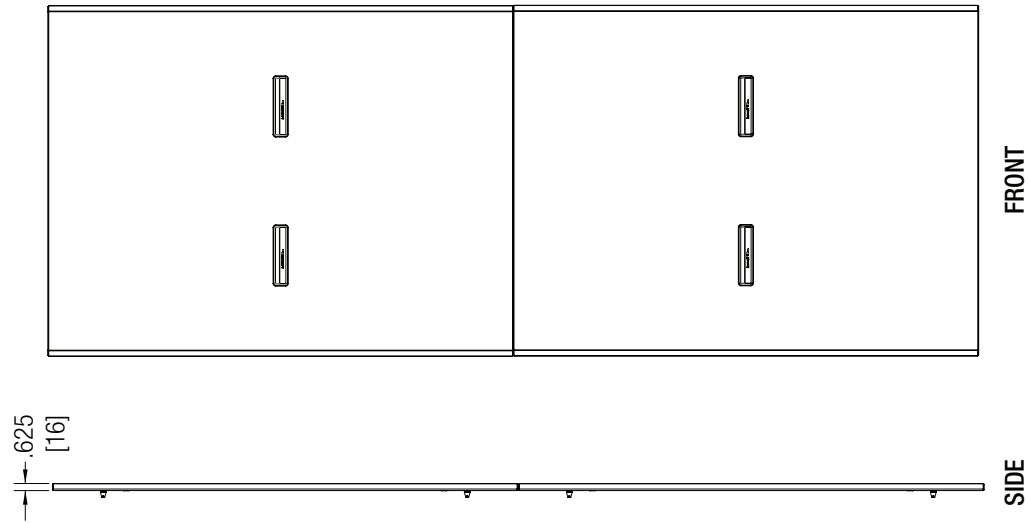

SDP Series (split)		Rack Depth
Model No.	RU	
▶ SDP-3532	35	32"
▶ SDP-4032	40	32"
▶ SDP-4432	44	32"
▶ SDP-5432 *	54	32"
▶ SDP-4036	40	36"
▶ SDP-4436	44	36"
▶ SDP-4042	40	42"
▶ SDP-4442	44	42"

\* Call for availability.

### FULL SIDE PANEL (1 PIECE PER SIDE)

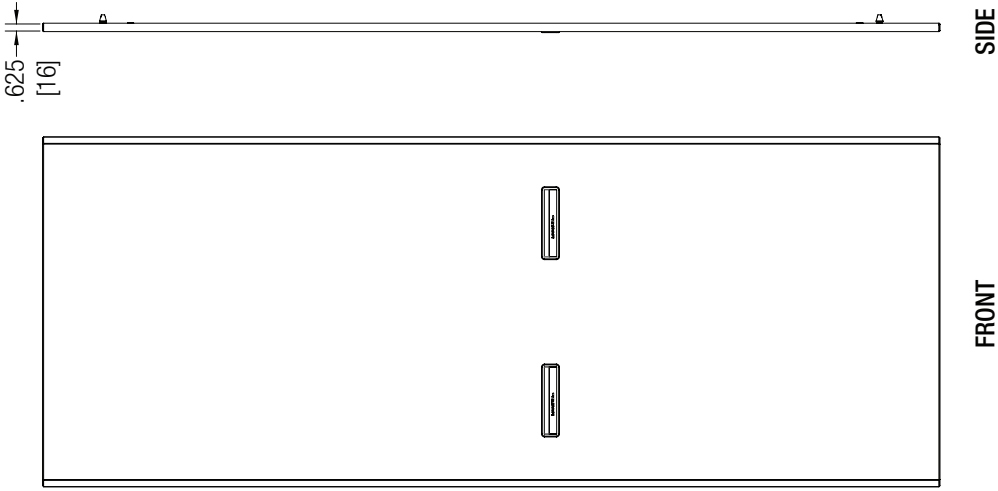

SDP Series (full)		Rack Depth
Model No.	RU	
▶ SDP-4022	40	22"
▶ SDP-4422	44	22"
▶ SDP-2427	24	27"
▶ SDP-3527	35	27"
▶ SDP-4027	40	27"
▶ SDP-4427	44	27"
▶ SDP-2432	24	32"

▶ = accessory fits LGR / LSGR Series models



Lowell strives to provide accurate information while reserving the right to change specifications and/or improve manufacturing methods without prior notification.  
©2024 Lowell Manufacturing Co., 100 Integram Dr., Pacific MO 63069, USA / tel. 800.325.9660 / tel. 636-257-3400 / www.lowellmfg.com



# SERIES SPECIFIC ACCESSORIES — MOBILE BASES

Dimensions are inches and [mm] unless stated otherwise.

**LMB Series**  
Mobile Base  
w/standard casters

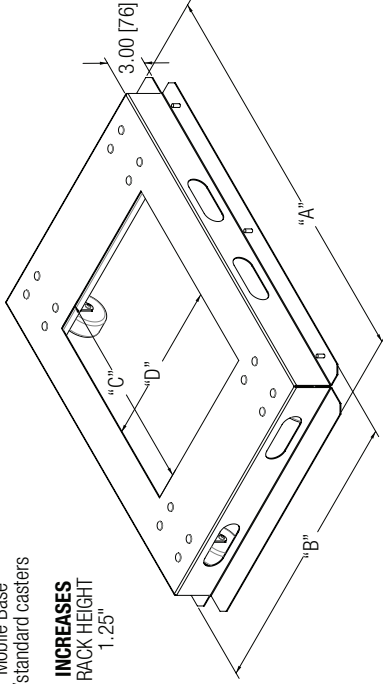

**LMB Series Summary**

Model No.	Rack Depth	"A" Overall Depth	"B" Overall Width	"C" Opening Depth	"D" Opening Width	Total Caster Load Rating
▶ LMB-27	27	26.75 [679]	22.81 [579]	12.97 [329]	11 [279]	1400 lbs.
▶ LMB-32	32	31.75 [806]	22.81 [579]	12.97 [329]	16 [406]	1400 lbs.
▶ LMB-36	36	35.75 [908]	22.81 [579]	12.97 [329]	20 [508]	1400 lbs.
▶ LMB-42	42	41.75 [1060]	22.81 [579]	12.97 [329]	26 [660]	1400 lbs.

**DO NOT USE WITH SEISMIC CERTIFIED RACKS**

**LMB--F Series**  
Mobile Base  
w/fine floor casters

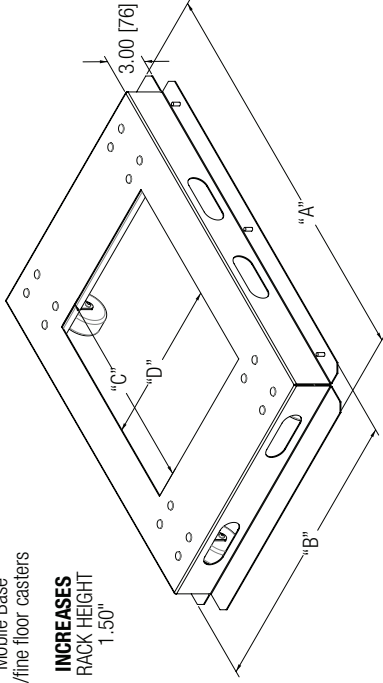

**LMB--F Series Summary**

Model No.	Rack Depth	"A" Overall Depth	"B" Overall Width	"C" Opening Depth	"D" Opening Width	Total Caster Load Rating
▶ LMB-27F	27	26.75 [679]	22.81 [579]	12.97 [329]	11 [279]	800 lbs.
▶ LMB-32F	32	31.75 [806]	22.81 [579]	12.97 [329]	16 [406]	800 lbs.
▶ LMB-36F	36	35.75 [908]	22.81a [579]	12.97 [329]	20 [508]	800 lbs.

▶ = accessory fits LGR / LSGR Series models



Lowell strives to provide accurate information while reserving the right to change specifications and/or improve manufacturing methods without prior notification.  
©2024 Lowell Manufacturing Co., 100 Integram Dr., Pacific MO 63069, USA / tel. 800.325.9660 / tel. 636-257-3400 / www.lowellmfg.com

# SERIES SPECIFIC ACCESSORIES — ADDITIONAL RACK RAILS

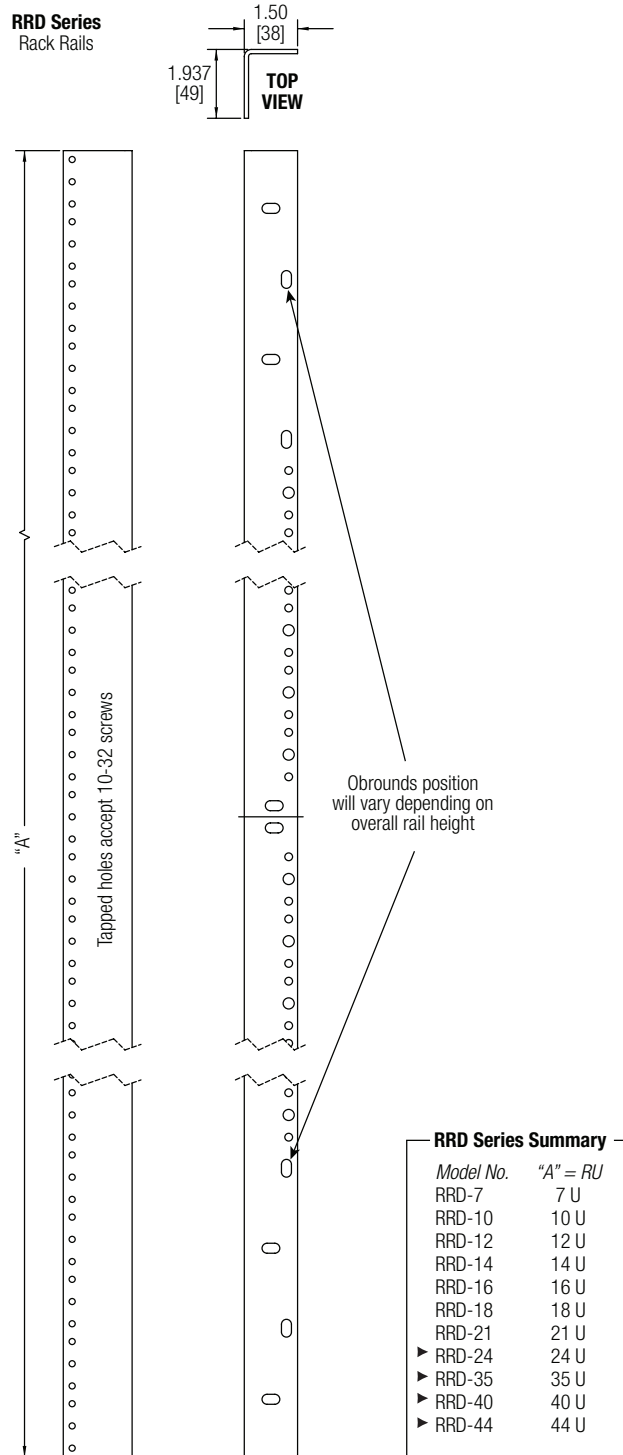

▶ = accessory fits LGR / LSGR Series models