

# JR410 Series

## 4" High-Compliance Single Cone Driver w/Transformer Options



Lowell's JR410 Series is an industry standard 4-inch (EIA 5-inch) high-compliance single cone driver providing wide frequency response and wide dispersion for solid performance in commercial paging and background music systems. Engineered to provide even coverage using fewer drivers the series is suitable for commercial, industrial and institutional applications including offices, public buildings, airport corridors, and educational or medical facilities. The driver's small size and broadbeam width of 170 degrees make the series especially useful in rooms with low ceilings.

### DESCRIPTION

The 4-inch 15W high-compliance single cone driver features a 10 oz. ceramic magnet, 1-inch copper voice coil, treated cloth surround, and 20-gauge stamped steel basket with zinc plating. The series includes models with one of three factory-mounted transformers (25V/70V 5W, 70V 4W, or 70V 8W). Assembled in the USA with global components.

### A&E SPECIFICATIONS – DRIVER

High-compliance 4-inch (EIA 5-inch) driver shall be Lowell Model JR410. It shall be of the permanent magnet type having a paper cone with a treated cloth surround. It shall be capable of producing a uniform audible frequency response over the range of 67Hz-16kHz ( $\pm 6$ dB) and 53Hz-20kHz ( $\pm 8$ dB) with a dispersion angle of 170 degrees @2000Hz ( $-6$ dB). Average sensitivity shall measure 90.8dB SPL (at 1W/1M). Rated power rating shall be 15 watts RMS. The voice coil shall have a 1-inch diameter and shall operate in a magnetic field derived from a strontium ferrite (ceramic) magnet with 10 oz. nominal weight. Voice coil impedance shall be 8 ohms. The driver shall have a structurally reinforced stamped 20-gauge steel frame to maintain precise mechanical alignment and shall provide facilities for mounting a transformer. The driver shall have an overall diameter of 5.00-inch with four round holes equally spaced at 90 degrees on 4.72-inch diameter mounting bolt circle. Driver depth shall be 2.12-inches. External metal parts shall be zinc-plated to resist rust and corrosion. Assembled in the USA with global components.

### A&E SPECIFICATIONS – DRIVER+TRANSFORMER

The high-compliance 4-inch (EIA 5-inch) driver and transformer shall be Lowell Model JR410-T\_\_\_\_\_. The driver shall be of the permanent magnet type with a paper cone, treated cloth surround, 1-inch diameter voice coil (8 ohm impedance), 10 oz. ceramic magnet, 20-gauge steel frame with 5.00-inch diameter and four holes spaced at 90 degrees on 4.72-inch diameter mounting bolt circle. It shall have a dispersion angle of 170 degrees conical @2000Hz octave ( $-6$ dB). External metal parts shall be zinc-plated. Factory-mounted transformer shall be \_\_\_\_\_ voltage with selectable taps at \_\_\_\_\_ W. Transformer response shall be 50Hz-15kHz ( $+1$ dB) with insertion loss  $<1$ dB. Assembly's average sensitivity shall measure \_\_\_\_\_ dB SPL (at 1W/1M) and power rating shall be 15W RMS. Frequency response shall be \_\_\_\_\_ Hz-\_\_\_\_\_ kHz ( $\pm 6$ dB) and \_\_\_\_\_ Hz-20kHz ( $\pm$ \_\_\_\_\_ dB). It shall have an overall depth of \_\_\_\_\_ inches. Assembled in the USA with global components.

## JR410 SERIES OVERVIEW

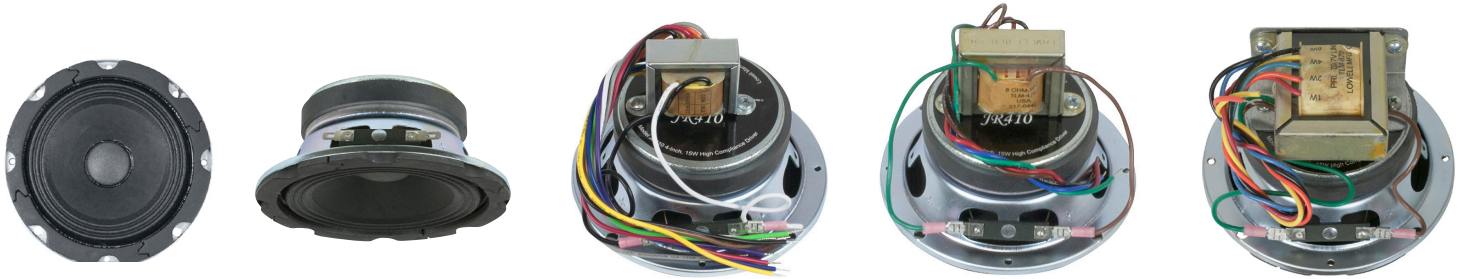



MODEL	JR410	JR410-T72	JR410-T470	JR410-T870
<b>Driver / Size</b>	4-inch (EIA 5-inch)	4-inch (EIA 5-inch)	4-inch (EIA 5-inch)	4-inch (EIA 5-inch)
<b>Driver Type</b>	High-compliance single cone	High-compliance single cone	High-compliance single cone	High-compliance single cone
<b>Magnet</b>	10-oz., ceramic	10-oz., ceramic	10-oz., ceramic	10-oz., ceramic
<b>Voice Coil</b>	1-in. dia., copper wire	1-in. dia., copper wire	1-in. dia., copper wire	1-in. dia., copper wire
<b>Power Rating</b>	15W RMS	15W RMS	15W RMS	15W RMS
<b>Transformer</b>	---	25V/70V	70V	
<b>Primary Taps</b>	---	0.25, 0.5, 1, 2, and 5W	0.5, 1, 2, and 4W	1, 2, 4, and 8W
<b>Frequency Response</b>	67Hz–16kHz (±6dB) 53Hz–20kHz (±8dB)	67Hz–16kHz (±6dB) 57Hz–20kHz (±7.4dB)	66Hz–16kHz (±6dB) 57Hz–20kHz (±7.9dB)	75Hz–15.7kHz (±6dB) 57Hz–20kHz (±7.4dB)
<b>Average SPL</b>	90.8dB (@1W/1M)	90.8dB (@1W/1M)	90.2dB (@1W/1M)	91.4dB (@1W/1M)
<b>Maximum SPL</b>	102.6dB <i>Calculated based on power rating and measured sensitivity.</i>	97.8dB <i>Calculated based on 5W max. transformer power tap and measured sensitivity.</i>	96.2dB <i>Calculated based on 4W max. transformer power tap and measured sensitivity.</i>	100.4dB <i>Calculated based on 8W max. transformer power tap and measured sensitivity.</i>
<b>Dispersion Angle</b>	170 degrees conical @2kHz octave (-6dB)	170 degrees conical @2kHz octave (-6dB)	170 degrees conical @2kHz octave (-6dB)	170 degrees conical @2kHz octave (-6dB)
<b>Mounting Depth*</b>	2.12 inches	3.56 inches	3.77 inches	3.83 inches
<b>Outside Diameter</b>	5.00 inches	5.00 inches	5.00 inches	5.00 inches
<b>Net Weight</b>	1.7 lbs.	2.1 lbs.	2.3 lbs.	2.6 lbs.

\* Mounting Depth: Minimum depth required for assembly to be rear-mounted to grille in an enclosure.

**NOTE ON SPEAKER SPACING:** Conical dispersion measurements are provided for comparison with other speakers. To determine correct speaker spacing, see the technical paper "Distributed System Speaker Spacing for the Integrator" ([www.Lowellmfg.com](http://www.Lowellmfg.com)) which explains the difference between conical and linear dispersion and the measurements to use for best results online under Resources – White Papers. For quick calculations, a calculator for speaker spacing is also available online under Resources – Interactive Tools.

### YOU MAY ALSO LIKE — Speaker Assemblies featuring JR410-T72 with pre-mounted grille (see speaker assembly spec sheets for details)

 <p><b>Assembly D1410-72 Features:</b></p> <p><u>DRIVER+XFMR:</u> JR410-72</p> <p><u>GRILLE:</u> Model: WB-4 Type: Round screw-mount Finish: White powder coat</p>	 <p><b>Assembly D3410-72 Features:</b></p> <p><u>DRIVER+XFMR:</u> JR410-72</p> <p><u>GRILLE:</u> Model: CN-4M Type: Round torsion-mount Finish: White powder coat</p>	 <p><b>Assembly D6410-72 Features:</b></p> <p><u>DRIVER+XFMR:</u> JR410-72</p> <p><u>GRILLE:</u> Model: SG-4 Type: Square screw-mount Finish: White powder coat</p>
---	--	---

## TECHNICAL DRAWINGS

Dimensions are inches and [mm] unless stated otherwise.

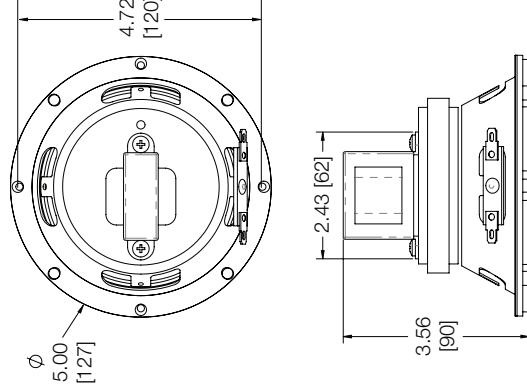
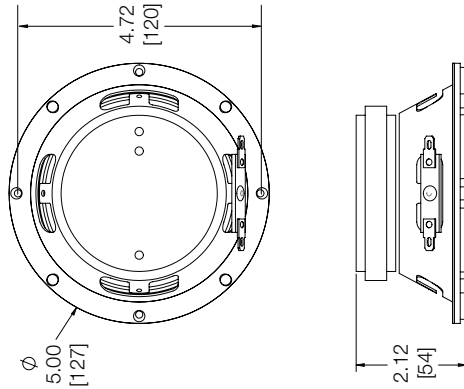

**JR410-T72**  
 4" 15W Driver  
 25V/70V 5W Transformer

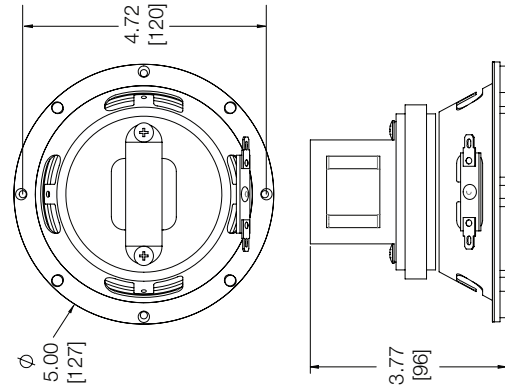
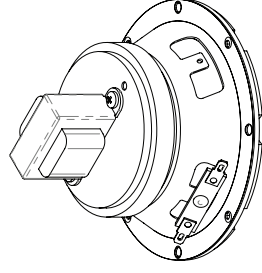

**JR410-T470**  
 4" 15W Driver  
 70V 4W Transformer

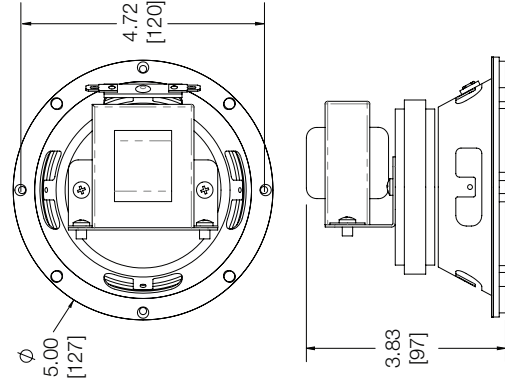
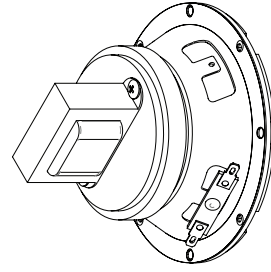

**JR410-T870**  
 4" 15W Driver  
 70V 8W Transformer

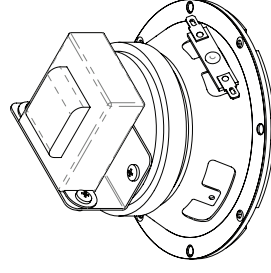

## JR410 DRIVER – POLAR DATA (HALF SPACE)

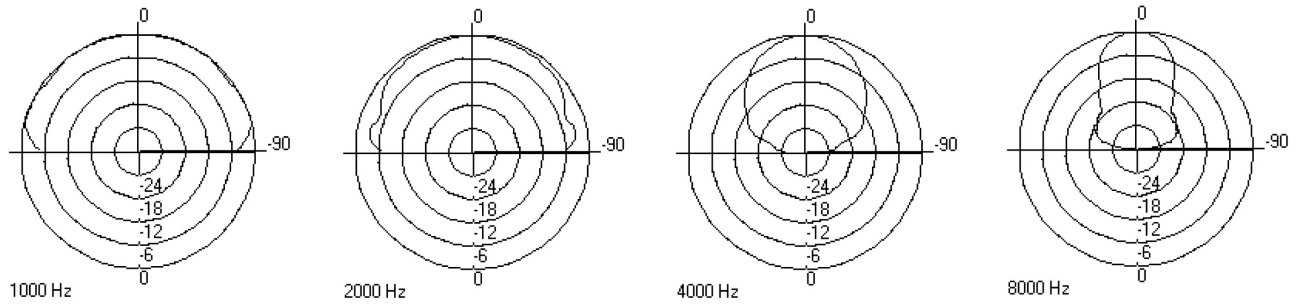

## JR410 DRIVER – SPL VS. FREQUENCY (1W/1M, HALF SPACE, ON-AXIS)

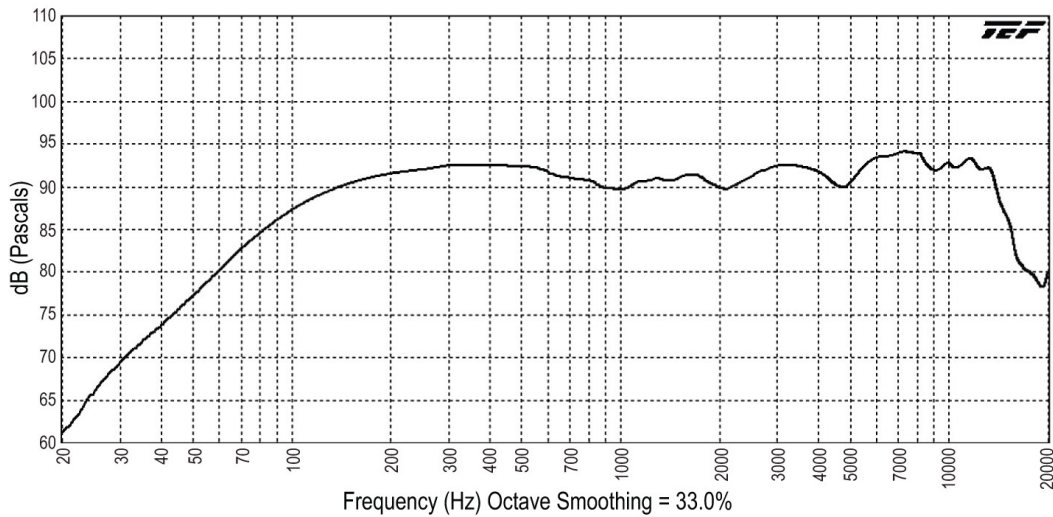

## JR410 DRIVER – IMPEDANCE

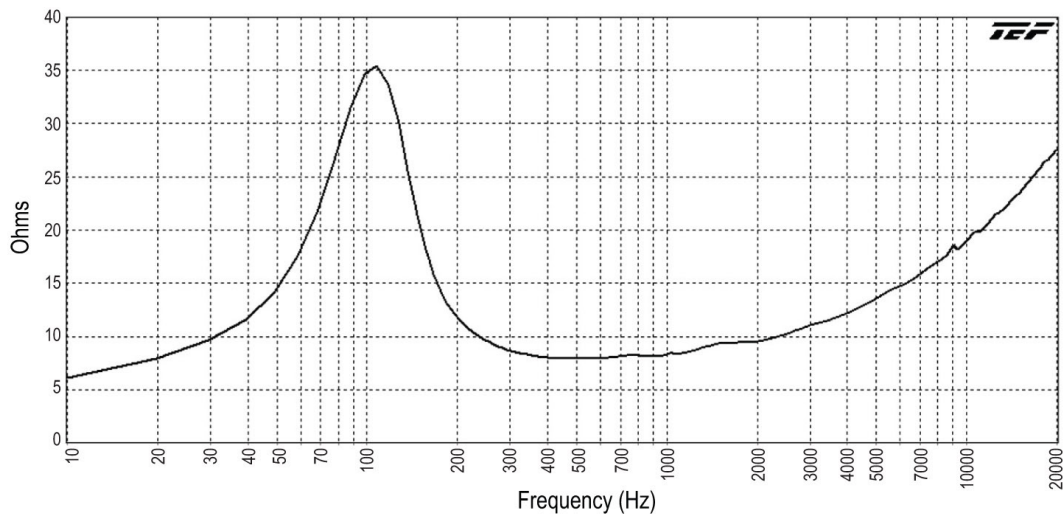

## JR410 DRIVER – SPECIFICATIONS

### PERFORMANCE:

Power Rating .....	15 watts RMS (nominal) measured per E.I.A. Standard RS-426B
Sensitivity .....	90.8dB log Average SPL (1W/1M) 102.6dB Maximum SPL (calculated based on power rating and measured sensitivity)
Impedance .....	Driver Nominal Impedance: 8 ohms Driver Minimum Impedance: 7.9 ohms @508Hz
Frequency Response .....	67Hz–16kHz (±6dB); 53Hz–20kHz (±8dB)
Dispersion Angle .....	170 degrees conical @2kHz octave (-6dB)

### PHYSICAL – WOOFER:

Cone .....	Paper with treated cloth surround
Magnet .....	10 oz. (264g), strontium ferrite ceramic
Voice Coil .....	1 in. (26mm) diameter, copper wire
Terminals .....	Quick disconnect type, spade lugs

### MECHANICAL:

Basket .....	20-gauge stamped steel with zinc plating
Outside Diameter .....	5.00 in. (127mm)
Mounting Bolt Circle.....	4.72 in. (120mm) with 4 round holes equally spaced at 90 degrees
Cutout Diameter .....	4.125 in. (105mm)
Mounting Depth .....	2.12 in. (54mm)
Net Weight.....	1.7 lbs. (0.76kg)

### THIELE-SMALL PARAMETERS:

Pe .....	15 W	Qts.....	0.627	BL.....	4.7 Tm	Sd.....	59.5 cm <sup>2</sup>
Fs .....	114.9 Hz	Qes.....	0.734	Efficiency, h.....	0.64 %	Mms .....	2.99 g
Xmax.....	-0.7 mm	Qms.....	4.31	Vas .....	3.2 liters	Cms.....	0.643 mm/N
Re .....	7.4 ohms						

SCOPE OF PERFORMANCE AND POWER TESTS: Lowell drivers and loudspeaker systems are tested to provide specifiers and contractors with data that reflects the performance of production products. Testing equipment includes the GoldLine TEF-20 analyzer (for performance measurements) and the LinearX LMS measurement system (for Thiele-Small Parameters).

Power Rating is tested based on EIA Standard RS-426B.

Frequency Response data is provided which is the measured frequency response range (defined by ±6dB) which is useful in predictive engineering calculations.

Sensitivity (SPL) data is presented in two ways:

1. Log Average SPL is a computer calculated log average of the SPL measured at 1 meter with 1 watt input over the stated frequency response range.
2. Maximum SPL is calculated based on the measured log average SPL and the 8ohm power rating of the speaker. Maximum SPL for speakers that do not include an 8ohm input, is calculated based on the measured log average SPL and the highest transformer power tap.

Dispersion Angle is defined as the angle of coverage that is no more than 6dB down from the on-axis value averaged over the 2000Hz octave band. Since speech intelligibility is very dependent upon the 2000Hz octave, this specification is quite useful in designing speech reinforcement systems that provide even coverage and speech intelligibility.

Thiele-Small Parameters for raw drivers are measured using the LinearX LMS measurement system. These parameters are useful in determining the optimum type and size of enclosure for a specific driver.

Polar Data is presented for the averaged one octave band surrounding the center frequencies of 1000Hz, 2000Hz, 4000Hz, and 8000Hz. Radial polar response curves show the relative change in sound pressure level as one moves from directly on-axis to an increasingly off-axis listening position. Since coaxial speaker drivers are symmetrical in the vertical and horizontal directions, only one set of polar plots will be presented for coaxial drivers and speaker systems incorporating coaxial drivers.

Impedance Data may be represented in four different ways depending on the particular model:

1. Nominal Impedance is the generally accepted impedance value for use in making comparisons with competitive products.
2. Impedance Curve is a graphical representation of the 8ohm driver impedance measured in the lab and gives the impedance of the device over the audio frequency range.
3. Minimum Impedance is the lowest impedance measurement of the 8ohm driver at a frequency within the specified frequency response range of the speaker.
4. Impedance Measured at 1kHz is the reading expected to be measured by a technician in the field using a typical industry 1kHz impedance meter.