

Model No.

LTS Series

1x2 Lay-in Tile Ceiling Loudspeaker

INCLUDES:

- 8-inch 15W dual cone driver
- 25V/70V dual-voltage transformer
- 1x2 frame w/7-in. square grille pattern
- 0.147 cu.ft. enclosure
- Volume control knob (VC model only)

Patented* integral T-bar supports neighboring (cut) ceiling tile



LTS SERIES SPEAKERS are pro systems made for quick installation in suspended lay-in tile ceilings. Featuring an 8" 15W dual cone driver, 25V/70V dual voltage transformer, 1x2 white frame with 7" square grille pattern, and 0.147 cu.ft. enclosure with or without volume control (VC) knob. The patented* 1x2 assembly features an integral T-bar support that replaces one-half of a 2x2 or one-fourth of a 2x4 ceiling tile.

FEATURES

PERFORMANCE: Ideal for applications providing commercial paging and/or background music.

DRIVER (MODEL 810): The 8" 15W dual cone driver with 10 oz. magnet provides a step up in full range performance from the commercial industry standard, delivering solid performance and value for paging and/or background music applications that require clear communications.

- Driver magnet: 10 oz. ceramic, 3/4" hard fiber whizzer cone, 1" voice coil, 20-gauge steel frame with zinc-plated finish
- Driver weight: 2.0 lbs.
- Driver depth: 2.84"

TRANSFORMER: Factory-wired dual voltage 25V/70V transformer with primary taps at 0.3, 0.6, 1, 2 and 5.5W.

GRILLE (1X2 FRAME): Square 7" grille pattern in frame with white powder finish. Includes holes in corners for code compliance tie-offs, and patented* integral T-bar to support the neighboring cut tile.

- The 1x2 grille assembly replaces one-half of a 2x2 or one-fourth of a 2x4 ceiling tile.

ENCLOSURE (8XD4): USA-certified steel enclosure with black powder finish.

- Volume: 0.147 cu.ft.
- Polyurethane foam disc
- Hand-adjustable volume control knob (VC model only)

INSTALLATION:

- Assembly Dimensions: 23.75"L x 12.75"W x 4.13"H
- Patented T-bar Support: Integral 2-foot T-bar attached to grille assembly supports the neighboring cut ceiling tile.
- Restraint Tabs: The assembly features four holes in side flanges of frame for code compliance tie-offs.
- Connections: Driver leads exit enclosure through a metal clamp for fast connections — just splice connecting wires, push inside the enclosure, and tighten clamp.

COMPLIANCE & CERTIFICATIONS:

- Made in the USA with USA-certified steel
- Trade Agreements Act (TAA) compliant
- Buy American Act (BAA) compliant
- UL pending



A&E SPECIFICATIONS

The loudspeaker for suspended lay-in tile ceilings (non-regular, flush) shall be Lowell Model No. _____.

The 1x2 assembly shall replace one-half of a 2x2 or one-fourth of a 2x4 ceiling tile and shall include an integral T-bar to support adjacent (cut) ceiling tile. Each speaker shall include a factory-mounted driver with transformer mounted to steel grille frame with white powder-coat finish. The driver shall be 8" dual cone with 15W power rating. It shall have a magnet weight of 10 ozs., frequency response of 54Hz-11.6kHz (± 6 dB); 50Hz-20kHz (± 6 dB) and average sensitivity of 97.9dB measured 1W/1M. The dual voltage transformer (25V/70V) shall feature primary taps at 0.3, 0.6, 1, 2 and 5.5W. The system shall include a steel backbox (0.147 cu.ft. volume) with leads exiting through a metal clamp, it _____ (shall/shall not) feature a hand-adjustable volume control knob, and it shall have a smooth-black powder-coat finish. The assembly shall be manufactured in the USA using USA-certified steel, and it shall be Trade Agreement Act (TAA) and Buy American Act (BAA) compliant.

LTS SERIES OVERVIEW

Model No.	Driver	Transformer	Taps	Enclosure	Grille Frame	Volume Control	Listed	Sensitivity*	Frequency Response	Dispersion**
LTS-810-72-BB	8" 15W dual cone	25V / 70V	.3, .6, 1, 2, 5.5W	.147 cu.ft.	1 x 2	---	pending	97.7 dB	134Hz-6kHz (± 6 dB) 104Hz-11.6kHz (± 10 dB)	90°
LTS-810-72-BB-VC	8" 15W dual cone	25V / 70V	.3, .6, 1, 2, 5.5W	.147 cu.ft.	1 x 2	yes	pending	97.7 dB	134Hz-6kHz (± 6 dB) 104Hz-11.6kHz (± 10 dB)	90°

* Average SPL @ 1W/1M; ** Conical @ 2kHz octave (-6dB)

DRIVER SPECIFICATIONS

Driver No.	Size	Power Rating	Type	Ceramic Magnet	Frequency Response	Dispersion @ 2000Hz(-6dB)	Voice Coil Impedance	Voice Coil Diameter	Sensitivity 1W/1M	Max SPL*	Driver Depth	Driver Weight
810	8 in.	15W	dual cone	10 oz.	54Hz-11.6kHz (± 6 dB) 50Hz-20kHz (± 6 dB)	95 degrees conical	8 ohms	1 in.	97.9dB avg.	109.7dB	2.84 in.	2.0 lbs.

*Calculated value 1M @ driver power rating. See spec sheet for driver 810 for additional information.

TEST METHODOLOGIES: Lowell speaker systems are thoroughly tested to provide specifiers and contractors with accurate data. Test equipment includes the Gold-Line TEF-20 analyzer.

- **POWER HANDLING:** specification is based on EIA Standard RS-426B.
- **FREQUENCY RESPONSE:** describes the usable response range defined by a ± 6 dB window, which is useful in predictive engineering calculations.
- **SENSITIVITY:** is a computer calculation of the log average sound pressure level (SPL) over the entire engineering bandwidth as given in the Frequency Response (± 6 dB).
- **MAXIMUM SPL:** is calculated based on the Power Handling and the measured log average Sensitivity where Maximum SPL = (Sensitivity @ 1W1M) + 10 log (Power Handling).
- **DISPERSION ANGLE:** is defined as the angle of coverage that is no more than 6dB down from the on-axis value averaged over the 2kHz octave band. Since speech intelligibility is dependent upon the 2kHz octave, this specification is useful in designing voice reinforcement and music systems that provide even coverage and intelligibility. The polar plots illustrate how the system performs when hung in free space (360°) or half-space (180°) in the case of a recessed speaker.

TECHNICAL DRAWINGS

Dimensions are inches and [mm] unless stated otherwise.

LTS-810-72-BB

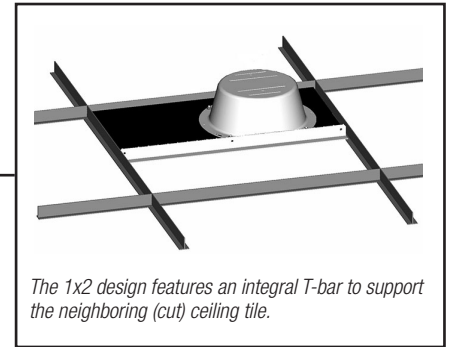
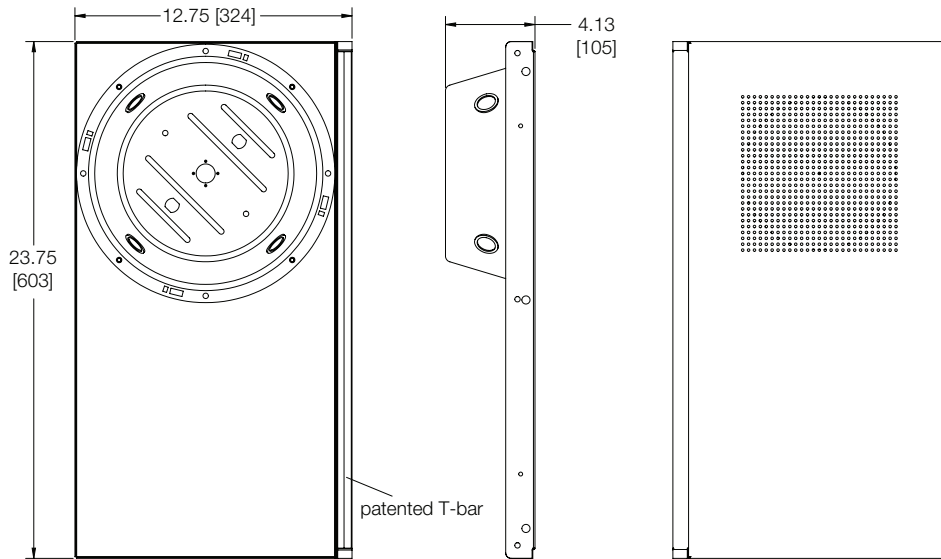

LTS-810-72-BB-VC

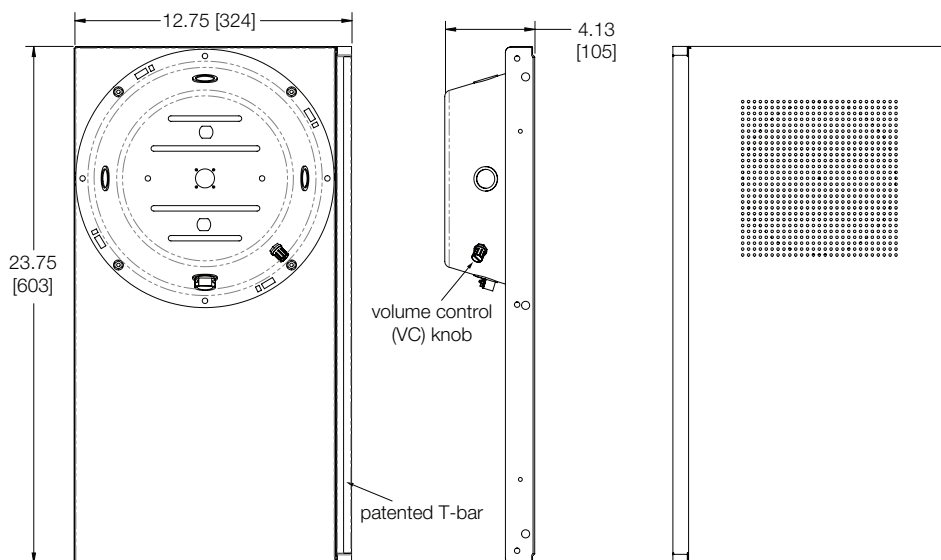

Volume control available on VC model only.