



Reversible unit can be mounted to a 19" rack as a slide-out shelf or shallow drawer.



MADE IN THE U.S.A. 100% CERTIFIED US STEEL

Slide-out shelf with vented base and integral pen trough can be inverted to mount as a shallow utility drawer.

FEATURES

- **Panel Space:** 1U or 1.75" [44]
- **Overall Depth:** 18"–33" [457-838] adjustable depth includes rear supports
- **Overall Width:** 19.00" [483]
- **Shelf Depth:** 16.25" [413]
- **Shelf Width:** 15.56" [395]
- **Construction:**
 - 16-gauge certified U.S. steel
 - Fully vented base for passive ventilation
 - Smooth black powder epoxy finish
 - Front and rear vents
 - Integral handle serves as a pen trough when the unit is mounted as a shelf.
 - Rear supports slide into position and extend to secure to rear rack rails.
- **Load Capacity:** 80 lbs. [36 kg]
- **Origin:** Made in the U.S.A.
- **Installation:**
 - Ships ready to install
 - For use with 19"–36"D rack
 - Mounts to front and rear rails of 19"W rack. Requires rear rack rails for support. Order rear rails for the rack if it does not have them already.
 - Rear supports can be extended up to 33"D.
 - When used as a shelf, its usable width is 15.56" and provides support for up to 80 lbs.
 - When mounted as a shallow drawer, it provides storage space with 1.58" usable height and 15.45" usable width.

A&E SPECIFICATIONS

The rack shall include Lowell RSD-116V reversible drawer/shelf, which shall be 16-gauge U.S. steel with fully vented base and smooth black powder epoxy finish. It shall measure 1U x 19.00"W x 18–33"D, including the extending rear support brackets. The unit shall be made to mount to front and rear rack rails as a shelf or shallow drawer. It shall have a load capacity of 80 lbs.

RSD SERIES SUMMARY

Model No.	Description	Rack Units	Panel Space	Shelf Usable Width	Drawer Usable Width	Adjustable Depth*	Weight
RSD-116	Reversible shelf/drawer	1U	1.75" [44]	15.56" [395]	15.45" [392]	18"–33" [457-838]	16 lbs.
RSD-116V	Reversible shelf/drawer w/vents	1U	1.75" [44]	15.56" [395]	15.45" [392]	18"-33" [457-838]	16 lbs.

*Including supports



TECHNICAL DRAWINGS

Dimensions are inches and [mm] unless stated otherwise.

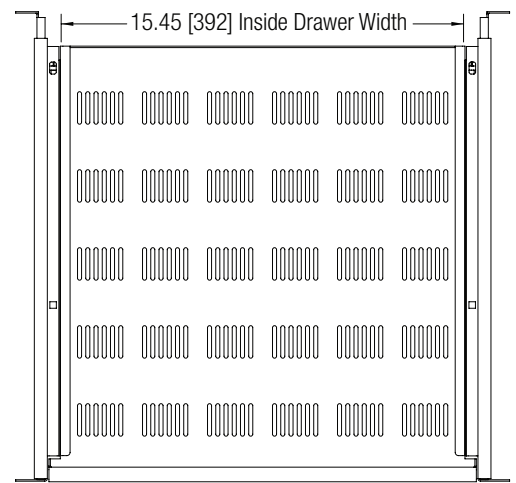
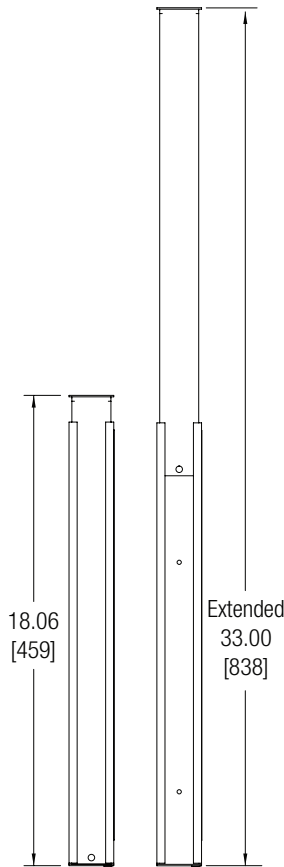
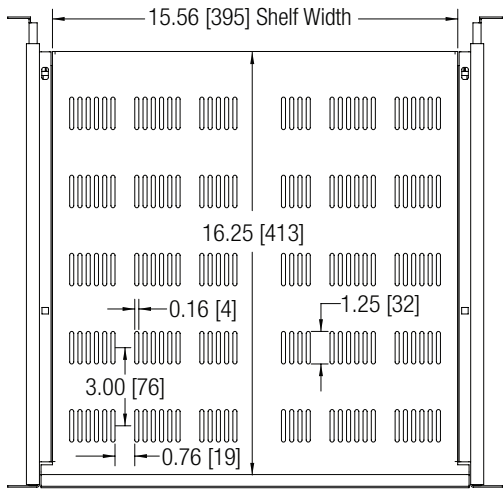
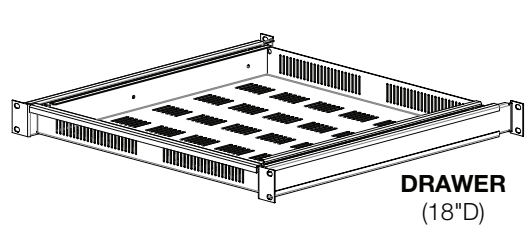
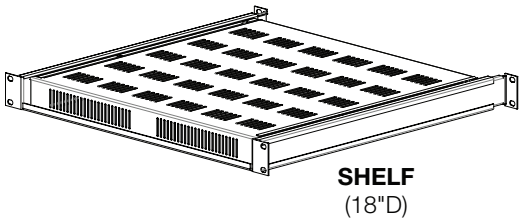

SHELF TOP

SIDE

DRAWER TOP

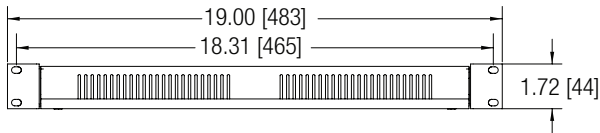

SHELF FRONT

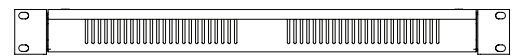

DRAWER FRONT

