



Chassis brackets help support heavy equipment mounted in 19" racks (servers, amplifiers, UPS, etc.). They're made primarily for use with two Lowell Z-rail kits (ZR or ZRN Series) in specified racks.

FEATURES:

- **Material:** 11-gauge certified US steel
- **Finish:** Black powder epoxy finish
- **Dimensions:** 1.72 in. x 3.00 in. x 20.00 in.
- **Load Capacity:** 200 lbs.
- **Origin:** Made in the U.S.A.

A&E SPECIFICATIONS:

The installation shall include Lowell chassis brackets model CHB-20, which shall be one pair of 11-gauge certified U.S. steel brackets with black powder epoxy finish, measuring 1.72 in. x 3.00 in. x 20.00 in. The brackets shall be made in the U.S.A. and have a load capacity of 200 lbs.

INSTALLATION:

Brackets work with hardware included with Lowell Z-rails. The brackets are installed front-to-rear of rack to help support heavy equipment up to 200 lbs. *NOTE: a total of two z-rail kits are required to mount one pair of CHB brackets.*

OPTIONS: (order separately)

- **ZR Series:** Z-rails for 23"W racks (LGR, LER Series)
- **ZRN Series:** Z-rails for 22"W racks (LGNR, LGVR Series)

SERIES OVERVIEW

Model No.	Description	Height	Width	Depth
▶ CHB-20	20" deep chassis bracket for use with z-rail	1.72 in.	3.00 in.	20.00 in.
CHB-26	26" deep chassis bracket for use with z-rail	1.72 in.	3.00 in.	26.00 in.
CHB-30	30" deep chassis bracket for use with z-rail	1.72 in.	3.00 in.	30.00 in.



TECHNICAL DRAWINGS

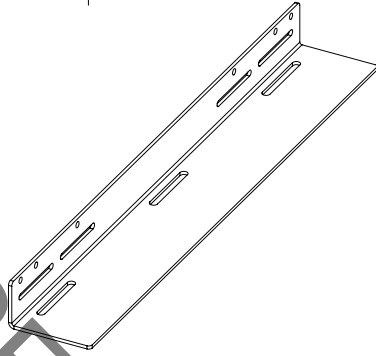
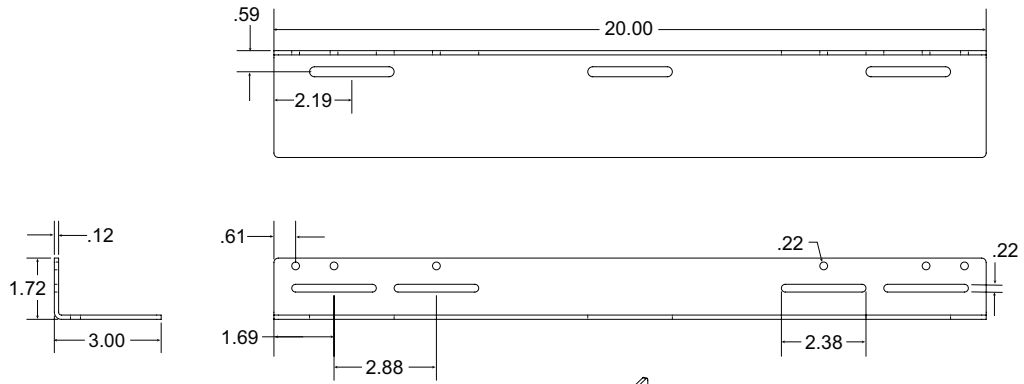

CLOSED OUT MODEL

