



FDC2-2T

Rackmount fan panel with universal input voltage (100VAC–240VAC) can be used almost anywhere in the world with the universal power supply that includes four plug adaptors. Variable-speed thermostat probe automatically activates fans, increasing and decreasing speed as it adjusts to ambient temperature. This power-saving feature ensures efficient fan operation, minimizing fan noise while saving wear and tear on the unit.

### FEATURES

- Fans have 3.15" [80mm] diameter and fan guards
- Total Airflow: 52cfm
- Noise Rating: 26dB
- UL Listed power supply with input 100-240 VAC, output 24VDC, 500mA, 6-ft. cord and four plug adaptors — NEMA 1-15 for North America (factory installed) Schuko CEE 7/16 for central Europe, BS1362 for the U.K., AS3112 for Australia and New Zealand.
- Thermostat probe that controls fan activation/deactivation
- Made in the U.S.A. with domestic and imported components.
- Fan Orientation: Exhaust (pulls air out of cabinet)

### A&E SPECIFICATIONS

The fan panel for rackmount installation shall be Lowell Model No. FDC2-2T which shall be U.S. steel finished in black powder epoxy paint with mounted fans and fan guards. The panel shall measure 2U x 19"W [486mm] and include two fans. Each fan shall have a 3.15" diameter and provide 52cfm airflow with 26dB noise rating when operating at highest speed. The fan panel shall include a 6-ft. [1829mm] cord with universal power supply and four plug adaptors — NEMA 1-15, Schuko CEE 7/16, BS1362 and AS3112. It shall also include a vari-speed thermostat probe to automatically activate fans, increasing and decreasing speed according to ambient temperature.

### SERIES OVERVIEW

Model No.	Description	Rack Units	Panel Height	Panel Width	Panel Depth	Fan Diameter	Fan Quantity	Total Airflow	Total Noise Rating	Universal Power Supply (four plug adaptors)	Thermostat probe
FDC2-2T	DC fan panel w/ thermostat	2	3.50"	19.00"	1.56"	3.15"	2	52cfm	26dBA	100-240VAC, 500mA	Yes
FDC4-2T	DC fan panel w/ thermostat	2	3.50"	19.00"	1.56"	3.15"	4	104cfm	29dBA	100-240VAC, 500mA	Yes

One rack unit (RU or U) = 1.75 inches or 44.45 mm. Some measurements may have been rounded.



**TECHNICAL DRAWINGS** Dimensions are inches and [mm] unless stated otherwise.

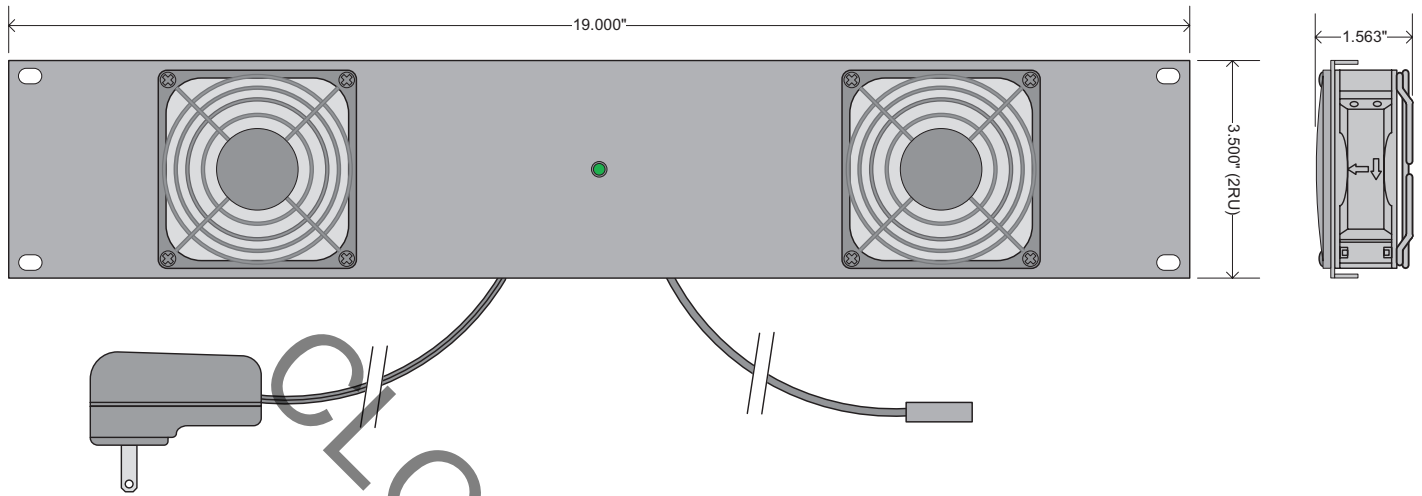

**THERMOSTAT PROBE**

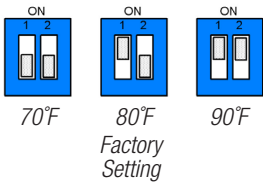

Thermostat probe automatically activates fans, increasing and decreasing speed as it adjusts to ambient temperature. Factory setting of 80°F [26.6°C] can be reset to 70°F or 90°F [21.1° or 32.2°C]

CLOSED-CYCLE MODEL

