

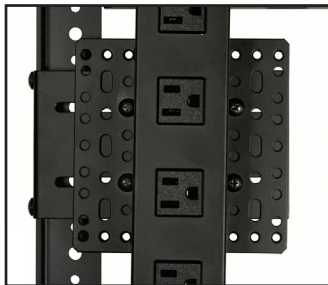

Mounting brackets for power strips and cable managers facilitate mounting them vertically in standard E.I.A. racks. The brackets are primarily for use with open frame two-post or four-post racks such as Lowell LRR Series, LXR Series or LVR Series.

FEATURES:

- **Material:** 16-gauge certified U.S. steel
- **Finish:** Black powder epoxy finish
- **Height:** 2U
- **Hardware:** Includes one pair brackets and hardware.
 - Four (4) 10-32 x 3/4" screws
 - Four (4) 10-32 x 1/2" screws
 - Four (4) 10-32 kep nuts
- **Installation:** Brackets can work with hardware typically included with Lowell power strips, including multi-hole style brackets.
- **Origin:** Made in U.S.A.



A&E SPECIFICATIONS:

The installation shall include Lowell mounting brackets model PCMB-6, which shall be one pair of 2U certified U.S. steel brackets with black powder epoxy finish. The brackets shall be capable of vertically mounting a power strip or cable manager to a two-post or four-post standard E.I.A. open frame rack. The brackets shall be made in the U.S.A.

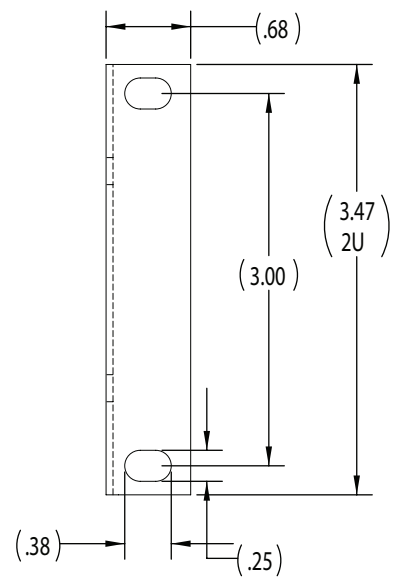
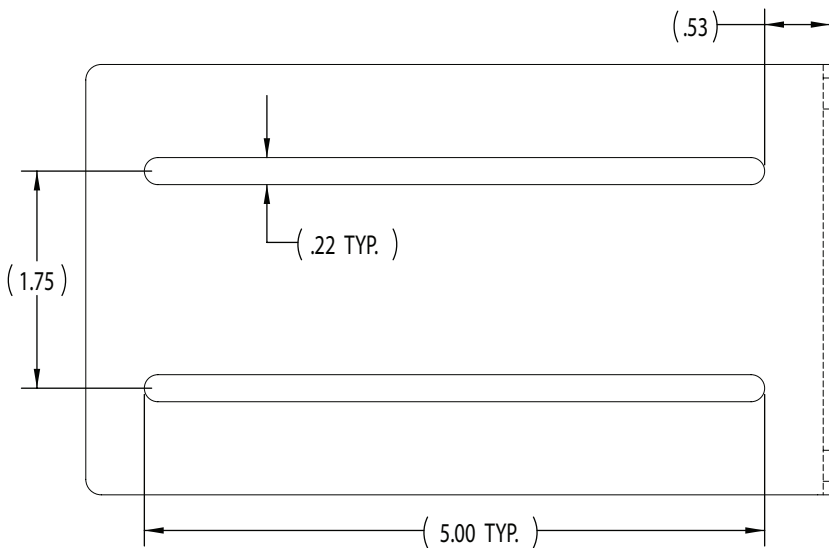
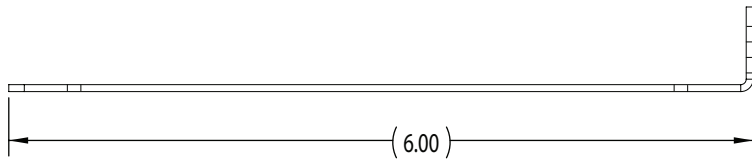
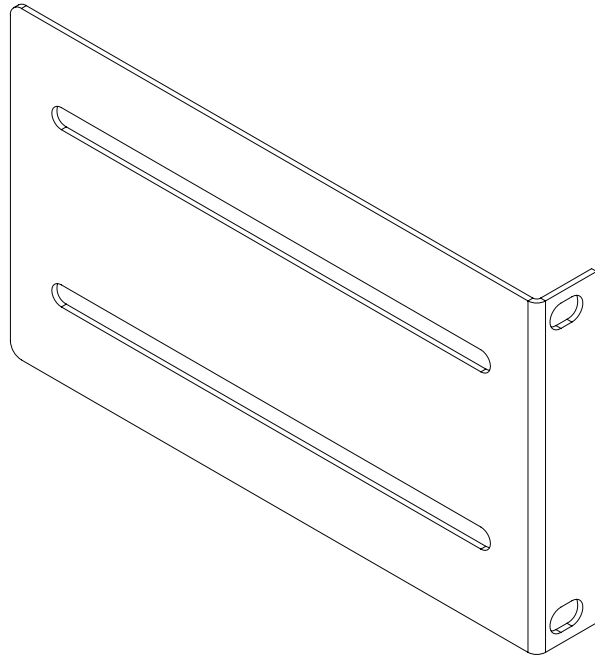

Measurements are shown as inches except where noted otherwise.

