

LXR Assembly Instructions

Position the top assembly, bottom assembly and the mounting rails as shown at the right.

The mounting rails are numbered consecutively in EIA rack units and are made for right hand or left hand applications.

Slide the 2 larger holes on the end of the mounting rails over the 2 ea. 5/16" threaded studs in the corners of the bottom assembly as shown in (detail A). Install the 5/16" hex nuts on the studs but do not tighten at this time.

Align the 10-32 tapped holes in the mounting rails with the countersunk holes in the front and rear of the assembly and insert a 10-32 x 1/2" flat head screw in each hole (detail B).

After the 10-32 screws are inserted and tightened in the rails, tighten the 5/16" nut on the threaded studs as shown in (detail A).

Repeat the above steps with all 4 rails on both the top and bottom assemblies.

Racks greater than 30RU will be supplied with a pair of side support brackets. These parts should be mounted to suit as shown.

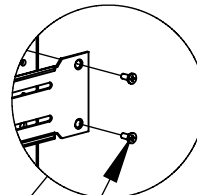
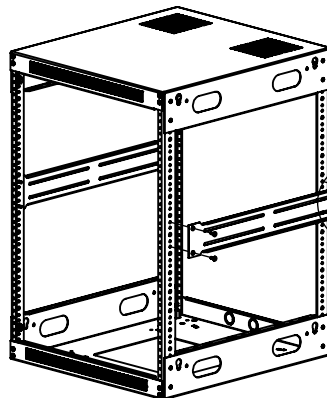

10-32 flat head screws in the countersunk holes secured with 10-32 keps nuts

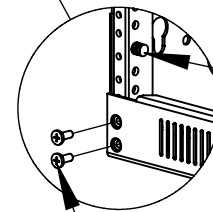

10-32 X 1/2" flat head screws

threaded stud

P/N: 18047

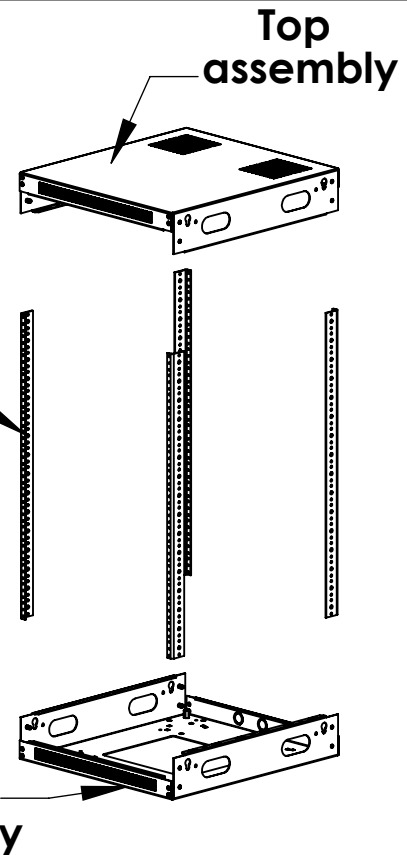

Bottom assembly

DETAIL A

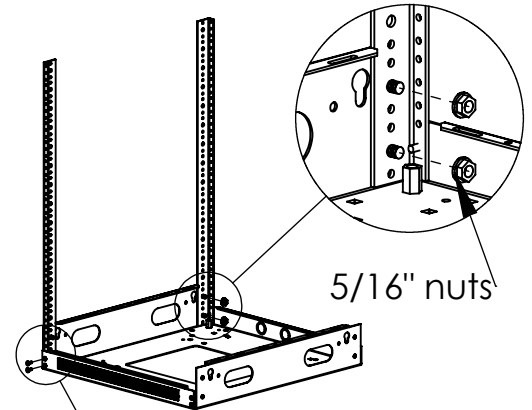

5/16" nuts

DETAIL B