

LDTR/ LWER/ LWSR Adjustable Mounting Rail Bracket Installation

Remove the two screws that mounts each of the mounting rail to the cabinet.

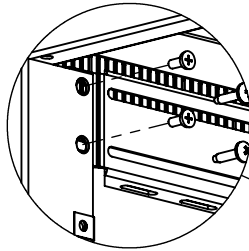

Position the rear rail mounting brackets behind the return flanges on the sides of the cabinet and align the slots in the brackets with the two countersunk holes in the cabinet. Insert a 10-32 x 1/2" flat head screw in each countersunk hole and secure each screw with a 10-32 keps nut.

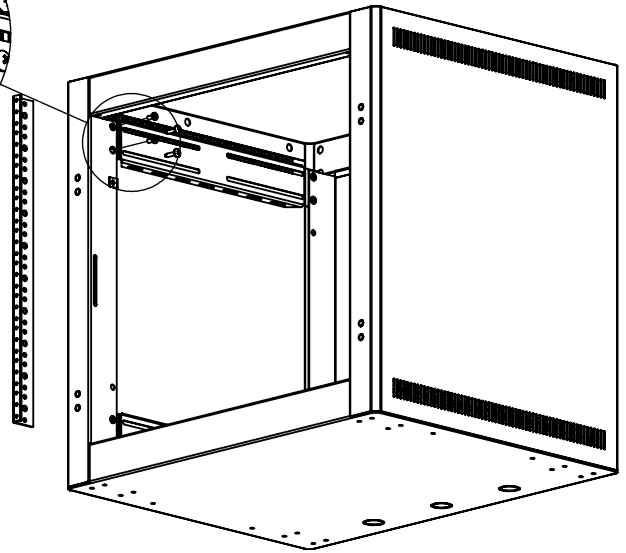

Position the mounting rail to suit holding it against the rear brackets. Align the holes in the mounting rails with the slots in the mounting brackets. Insert 4 each 10-32 x 5/8" truss head screw in the holes in each mounting rail. Use the screws removed in the first step with the additional screws supplied. Secure each screw with a 10-32 keps nut.

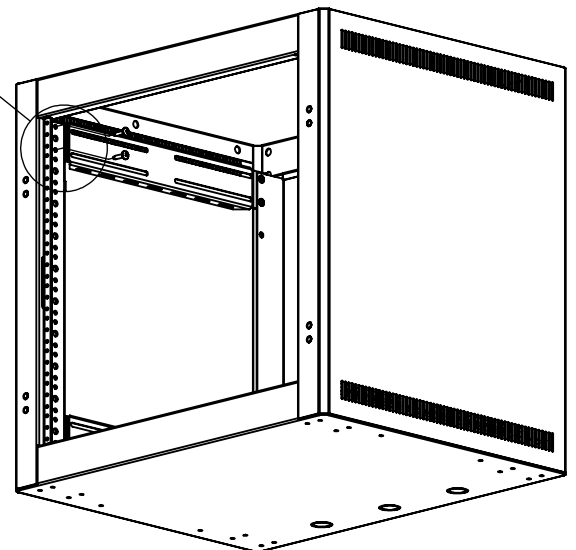
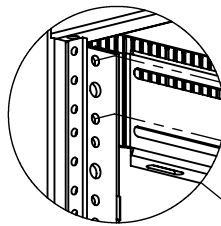

HARDWARE:

- 16 10-32 X 1/2" FLAT HD. SCREWS (P/N: 16028)
- 8 10-32 X 5/8" TRUSS HD. SCREWS (P/N: 13615)
- 24 10-32 KEPS NUTS (P/N: 4045)

P/N: 17991