



features.

- **Panel Space:** 1.75" [45] or 1U
- **Overall Width:** 19.00" [483]
- **Description:** A steel rackmount panel with two chrome handles provides a handhold to make it easier to maneuver cabinets with casters.
- **Construction:** 14-gauge U.S. steel
- **Flange:** 0.50 flange, top and bottom
- **Finish:** Smooth black powder epoxy finish
- **Handles:** Two chrome handles protrude 1-3/16"
- **Origin:** Made in the U.S.A. with certified U.S. steel

- **Installation:** The panel is to be mounted in the lower third of the rack to minimize tipping hazard.

⚠ CAUTION TIPPING HAZARD: Always use caution when moving a rack over a floor or threshold; instability may cause tipover.

requirements & specifications.

The rack shall include a panel with black finish and two chrome handles to facilitate maneuverability. The panel shall be 14-gauge steel with smooth black powder epoxy finish. It shall measure 19"W x 1.75"H (1U) and have a 0.50" flange on the top and bottom. The panel shall be mounted in the lower third of the rack.

technical drawings

Dimensions are inches and [mm] unless stated otherwise.

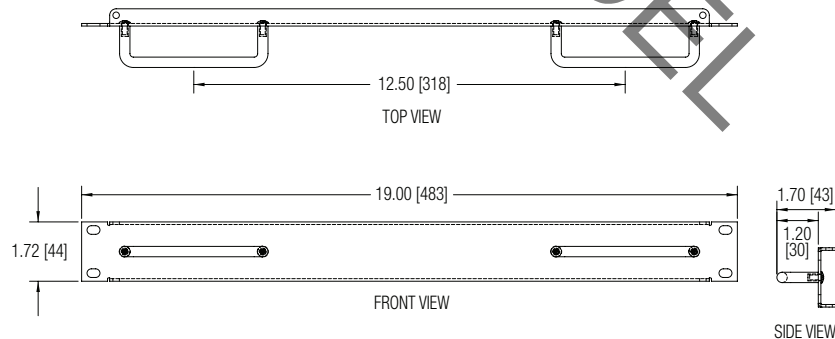

Model summary

Model No.	Panel Space	Overall Height*	Overall Width	Overall Depth	Material	Finish	Carton Pack
SPH-1	1U	1.75 [45]	19.00 [483]	0.50 [13]	14-gauge steel	Smooth black	1

Dimensions = inches [mm]
1U = 1.75"

