

Thermal management kit for LWR series racks includes two whisper fans with dual output thermo-cord (includes built-in thermostat probe) and magnetic vent blockers to direct airflow as needed. Ideal for cooling rack hot spots.

FEATURES

- Fans
 - Cast aluminum housing with black finish
 - Finger guards
 - Dual output thermo-cord with plug. The cord features an integral thermostat probe to control fan operation – automatically turning on/off when ambient temperature hits pre-set points. Fans activate when temperature is 86°F [30°C] and turn off when temperature is 72°F [22°C].
 - 4.7" fan diameter
 - 50 cfm airflow rating (per fan)
 - 28 dBA noise rating (per fan)
 - 5.5 watts power required (per fan)
 - Mount to side vent pattern of Lowell LWR Series wall-mount racks for quick field installation without drilling.
 - Can be field installed as either intake or exhaust.
- Magnetic vent blockers
 - Black magnetic panels fit over vents in LWR Series rack and are typically mounted on the inside
 - 0.60" thick material is magnetic on one side
 - Includes three panels: one panel measuring 19" x 1.5" and two panels measuring 16.5" x 5.25"
 - Field-trimmable



Model FW2-KITT-VB



Optional: Fan filter, model FW-ff.

A&E SPECIFICATIONS

The thermal management kit shall be Lowell Model No. FW2-KITT-VB which shall feature two single (4.7" sq. x 1.5"D) fans with cast aluminum housings and black finish. Each fan is rated at 50cfm airflow and 28dBA noise rating. The unit shall include fan guards and a dual output thermo-cord (with integral thermostat probe) and plug. It shall also include a total of three panels to block vents and help manage airflow in an LWR Series rack. The panels shall be magnetic on one side and measure 19" x 1.5" (one panel) and 16.5" x 5.25" (two panels).

SERIES OVERVIEW

Model No.	Panel Description	Height x Width (square)	Fan Quantity	Total Airflow	Total Noise Rating	Power Required	Cord Type
FW2-KIT-VB	Thermal management kit for LWR series racks	4.7 in. / 119mm	1	50cfm	28dBA	5.5 watts	standard (black)
FW2-KITT-VB	Thermal management kit for LWR series racks w/thermo cord	4.7 in. / 119mm	1	50cfm	28dBA	5.5 watts	thermostat (green)

Optional:

FW-FF	Fan filter
-------	------------

One rack unit (RU or U) = 1.75 inches or 44.45 mm. Some measurement have been rounded.



TECHNICAL DRAWINGS Dimensions are inches and [mm] unless stated otherwise.

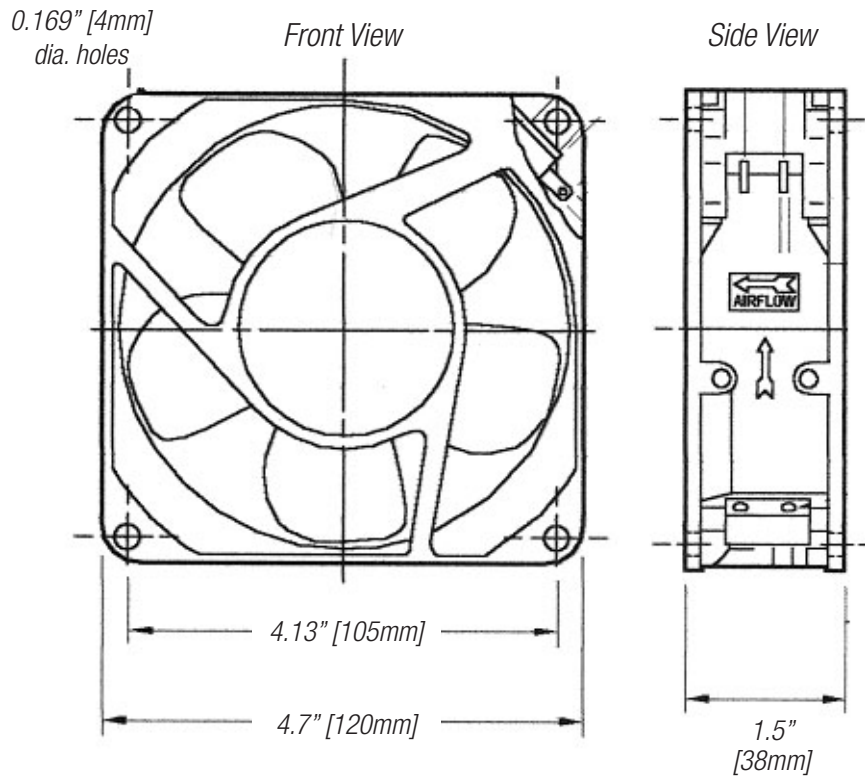

INSTALLATION GUIDE

