

Heard Everywhere Since 1947

Model No.

6A40

- **6.5 in. Coaxial Compression Driver**
- **Optional Transformer**

One of Lowell's "A-Series" drivers representing a deliberate move up in sound quality and performance over standard commercial coaxial drivers, the 6A40 is engineered for very high quality music and paging.

Features

- 40W coaxial 6.5 inch driver for music and paging
- Wide angle of sound distribution (150 degrees) over a large area with uniform response and clear audibility ensures complete coverage with minimum units.
- 10 oz. magnet coupled with 1 in. copper voice coil driving a polypropylene cone with half-roll rubber surround for long cone travel and good edge damping.
- Post-mounted tweeter is a 1in. balanced drive dome protected by Ferrofluid and a first order high-pass filter.
- Stamped 20 gauge steel frame with black enamel paint finish and zinc-plated backplate.
- Meets or exceeds all applicable EIA standards.
- Optional factory-wired transformer (Xfmr. No. TLM-870) has tap selections at 1, 2, 4, 8W (70V).
- Compatible with Lowell backboxes and architectural grilles. Not for use with torsion grille unless IX Series backbox is used.
- Optional factory wired transformer includes a bracket mounted to top of magnet for secure support.

A&E Specifications

The driver shall be Lowell Model No. _____, which shall be of the coaxial type having electrically independent high and low frequency transducers. The low frequency section shall have a 6.5 inch diameter polypropylene cone and the high frequency section shall have a tweeter with a 1" balanced-drive dome. A built-in electrical crossover network shall be employed to accomplish the proper frequency division between the two drivers. The crossover frequency shall be at 4000Hz with a first order high-pass filter. The driver shall be capable of producing a uniform audible frequency response over the range of 40Hz-20kHz±6dB with a dispersion angle of 150 degrees @2000Hz-6dB. The average sensitivity shall measure 85dB (SPL at 1W/1M). Rated power handling shall be 40 watts RMS. The



low frequency voice coil shall have a diameter of 1 inch and shall operate in a magnetic field derived from a ferrite (ceramic) magnet having a nominal weight of 10 oz. The high frequency voice coil shall have a diameter of 0.53 inches and operate in a magnetic field derived from a ferrite (ceramic) magnet having a nominal weight of 2 oz. The voice coil impedance shall be 8 ohms. The driver shall have a round, structurally reinforced stamped 20 ga. steel frame to maintain precise mechanical alignment and shall provide facilities for mounting a transformer. The driver shall have an overall diameter of 6.5 in. with eight obround holes equally spaced at 45 degrees on a 6.13 in. diameter mounting bolt circle. The mounting depth shall not exceed 3 in. (not including optional transformer). External metal parts shall be finished in black enamel paint or zinc plating to resist rust and corrosion.

For 70.7 volt distributed systems: (MODEL NO. 6A40-T870) The driver shall be equipped with a transformer, factory mounted and wired. The transformer's primary voltage shall be 70.7V and shall provide selectable power taps of 1, 2, 4, 8 watts. Transformer frequency response shall be 50Hz -15kHz±1dB, with maximum insertion loss of 0.8 dB.

Heard Everywhere Since 1947

0.3" x 0.195 obround holes
Fits grilles with mounting bolt circle of 7.625" - 7.688"

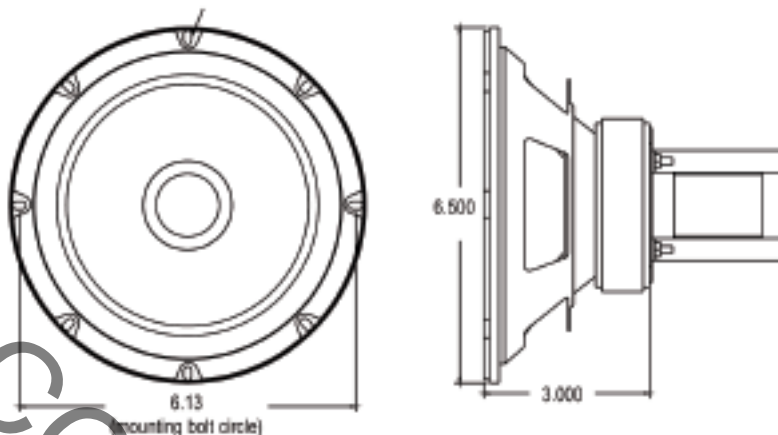

Driver Specifications

PERFORMANCE

Power Handling	40 watts RMS (nominal)
Sensitivity	91dB SPL (peak), 88dB SPL (avg) measured 2.83V @ 1m
Impedance	8 ohms (nominal), 8.1 ohms @170Hz (minimum)
Frequency Response	40Hz-20kHz (nominal), 40Hz-20kHz (±6dB)
Crossover Frequency	4000Hz, 1st order high-pass filter
Dispersion Angle	150° @ 2000Hz octave (-6dB)

PHYSICAL - WOOFER

Cone Material	Polypropylene with rubber half-roll (up) surround
Magnet Weight, Material	10oz. (283g), ferrite ceramic
Voice Coil Diameter, Material	1 inch (25mm), copper wire over aluminum former
Terminals	Quick disconnect type - spade lugs

PHYSICAL - TWEETER

Diameter	2.05 inch (52mm) housing with 1 inch (26mm) Dia. balanced-drive dome
Magnet Weight, Material	2oz. (57g), ceramic
Voice Coil Diameter, Material	0.53 inch (13.5mm), copper wire with Ferrofluid

MECHANICAL

Basket	20 gauge stamped steel with black enamel paint
Outside Diameter	6.5 inch (165mm)
Mounting Bolt Circle	6.13 inch (156mm) with 8 obround holes equally spaced at 45 degrees.
Cutout Diameter	5.7 inch (145mm)
Mounting Depth	3 inch (76mm)
Net Weight	2.1 lbs. (0.96kg)

THIELE-SMALL PARAMETERS

Pe.....40W	Qts.....0.53	BL.....6.4Tm	Sd.....20.6 in ² , 133cm ²
Fs.....51Hz	Qes.....0.66	Efficiency, h.....0.37%	Mms.....13g
Xmax.....0.1 in., 2.5mm	Qms.....2.8	Vas.....19 liters, 1160 cu.in	Cms.....0.76mm/N
Re.....6.5W			

Compatible Accessories (order separately)

IX610	Backbox CRS 10.063Dia x 10.063D, Direct mnt spkr-no load on grille + batting
CN8M	Grille CRS 12.5Dia, torsion mount, gentle contour design, white

Driver Model No. Summary

Model No.	Description	Size (in)	Depth (in)	Transformer Taps
6A40	40W coaxial compression driver	6.5	3	---
6A40-T870	40W coaxial compression driver w/transformer	6.5	5.4	1, 2, 4, 8W (70V)

Heard Everywhere Since 1947

Scope of Lowell Performance & Power Tests

Lowell drivers and loudspeaker systems are tested to provide specifiers and contractors with data that reflects the performance of production products. Testing equipment includes the GoldLine TEF-20 analyzer (for performance measurements) and the LinearX LMS measurement system (for Thiele-Small Parameters).

Power Handling capability is tested based on EIA Standard RS-426B.

Frequency Response data is provided which is the measured frequency response range (defined by + 6dB) which is useful in predictive engineering calculations.

Sensitivity (SPL) data is presented in two ways: Log Average SPL is a computer calculated log average of the SPL measured at 1 meter with 1 watt input over the stated frequency response range. Maximum SPL is calculated based on the measured log average SPL and the 8-ohm power rating of the speaker. Maximum SPL for loudspeakers which do not include an 8 ohm input, is calculated based on the measured log average SPL and the highest transformer power tap.

Dispersion Angle is defined as the angle of coverage that is no more than 6dB down from the on-axis value averaged over the 2000Hz octave band. Since speech intelligibility is very dependent upon the 2000Hz octave, this specification is quite useful in designing speech reinforcement systems that provide even coverage and speech intelligibility.

Thiele-Small Parameters for raw drivers are measured using the LinearX LMS measurement system. These parameters are useful in determining the optimum type and size of enclosure for a specific driver.

Impedance data is presented in three ways: Nominal Impedance is the generally accepted impedance for use in making comparisons with competitive products, the Impedance Curve is a graphical representation of the impedance that is measured in the lab and gives the impedance of the device over the audio frequency range, Minimum Impedance is the lowest impedance measurement at a frequency within the specified frequency response range of the speaker. If a line matching transformer is included in the speaker assembly, relative impedance curves of the primary windings of the transformer when loaded by the driver may be shown.

Polar data is presented for the averaged one octave band surrounding the center frequencies of 1000Hz, 2000Hz, 4000Hz, and 8000Hz. Radial polar response curves show the relative change in sound pressure level as one moves from directly on-axis to an increasingly off-axis listening position. Since coaxial speaker drivers are symmetrical in the vertical and horizontal directions, only one set of polar plots will be presented for coaxial drivers and speaker systems incorporating coaxial drivers. Vertical and horizontal polar plots will be presented for two-way speaker systems that incorporate separate low frequency and high frequency drivers.

