



Model No.

# LPTR4-1623

## Pull & Turn Rack

Panel Space:	16U or 28.00" [711]
Overall Height:	30.65" [779]
Overall Depth:	23.69" [602]
Pulled-out Depth:	46.67" [1185]
Overall Width:	19.13" [486]
Load Capacity:	200 lbs. [91 kg]



**PULL & TURN RACK** for built-in applications. Rack slides forward on support rails in base, then rotates left or right, locking at 60 or 90 degrees, providing superior access to equipment connections. Ships unassembled (two cartons).



*Rack slides forward on four support rails in base, then rotates left or right, locking at 60 or 90 degrees.*

## FEATURES

**BOTTOM SLIDE RAILS:** Four (4)

**CONSTRUCTION:** 14-ga. certified U.S. steel base and 11-ga. corner post rails with smooth black powder epoxy finish.

**MOUNTING RAILS:** Includes four (16U) 11-ga. steel corner post mounting rails tapped 10-32 with bi-directional numbered RU increments to mount in either direction, plus two rear rails (14U) for wire tie-off.

**CABLE MANAGEMENT:** Six rear cable lacing bars.

**HARDWARE:** Pilot point screws with captive washers for quick assembly

**COMPLIANCE:** EIA/TIA compliant. RoHS compliant.

**LOAD CAPACITY:** Four (4) bottom slide rails support total load capacity of 200 lbs.

**INSTALLATION:** The base can be mounted flush or recessed up to 1.75" to allow room for equipment knobs. Leave sufficient room at sides for rack rotation.

**OPERATION:** Remove front finishing panel to unlock rack, grasp rails and pull rack firmly towards you, sliding it along rails in base (locks when fully forward). To rotate, press center button to release turntable and rotate left or right (locks at 60 and 90 degrees). To return, rotate back to 0 degrees and depress right tab to release lock and slide back into base. Re-install front finishing panel to secure rack in rolled-back position.

### OPTIONAL:

- Steel top cover, black (LPTR-TC)
- Zero-space shelf, black (LPTR-NS)

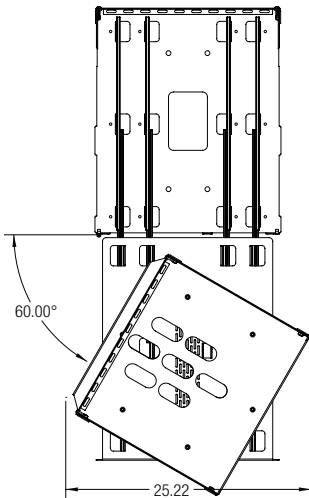

## A&E SPECIFICATIONS

The EIA/TIA compliant 19" equipment rack shall be Lowell LPTR4-1623 with overall dimensions of 30.65"H x 23.69"D x 19.13"W and usable height of 16 rack units. Rack construction shall be certified U.S. steel—14-gauge base with 11-gauge corner post rails tapped 10-32—with smooth black powder epoxy finish. The rack shall slide forward on four (4) rails in the base, and shall rotate and lock at 60 and 90 degrees. Base shall feature multiple obrounds for ventilation. The rear shall include six cable lacing bars. The rack shall support a load capacity of 200 lbs. It shall be manufactured in the U.S.A. and ship unassembled.

## OPTIONAL ACCESSORIES

- The rack shall include zero-space shelf LPTR-NS.
- The rack shall include steel top LPTR-TC.

## LPTR SERIES SUMMARY

Model No.	Post Mtg Rails (4)	Rear Tie Rails (2)	Bottom Slide Rails	Overall Depth	Pulled-out Depth	Usable Depth	Overall Height	Usable Height	Overall Width	Side Brackets	Load Capacity
LPTR2-1019	10 U	10 U	2	19.68 [500]	38.70 [983]	19.00 [483]	20.15 [512]	17.50 [445]	19.13 [486]	---	125 lbs.
LPTR2-1219	12 U	12 U	2	19.68 [500]	38.70 [983]	19.00 [483]	23.65 [601]	21.00 [533]	19.13 [486]	---	125 lbs.
LPTR2-1419	14 U	12 U	2	19.68 [500]	38.70 [983]	19.00 [483]	27.15 [690]	24.50 [622]	19.13 [486]	---	125 lbs.
LPTR2-1619	16 U	14 U	2	19.68 [500]	38.70 [983]	19.00 [483]	30.65 [779]	28.00 [711]	19.13 [486]	---	125 lbs.
LPTR2-2119	21 U	18 U	2	19.68 [500]	38.70 [983]	19.00 [483]	39.40 [1001]	36.75 [933]	19.13 [486]	---	125 lbs.
LPTR2-2419	24 U	23 U	2	19.68 [500]	38.70 [983]	19.00 [483]	44.65 [1134]	42.00 [1067]	19.13 [486]	Y	125 lbs.
LPTR4-1019	10 U	10 U	4	19.68 [500]	38.70 [983]	19.00 [483]	20.15 [512]	17.50 [445]	19.13 [486]	---	250 lbs.
LPTR4-1219	12 U	12 U	4	19.68 [500]	38.70 [983]	19.00 [483]	23.65 [601]	21.00 [533]	19.13 [486]	---	250 lbs.
LPTR4-1419	14 U	12 U	4	19.68 [500]	38.70 [983]	19.00 [483]	27.15 [690]	24.50 [622]	19.13 [486]	---	250 lbs.
LPTR4-1619	16 U	14 U	4	19.68 [500]	38.70 [983]	19.00 [483]	30.65 [779]	28.00 [711]	19.13 [486]	---	250 lbs.
LPTR4-2119	21 U	18 U	4	19.68 [500]	38.70 [983]	19.00 [483]	39.40 [1001]	36.75 [933]	19.13 [486]	---	250 lbs.
LPTR4-2419	24 U	23 U	4	19.68 [500]	38.70 [983]	19.00 [483]	44.65 [1134]	42.00 [1067]	19.13 [486]	Y	250 lbs.
LPTR4-2819	28 U	24 U	4	19.68 [500]	38.70 [983]	19.00 [483]	51.65 [1312]	49.00 [1245]	19.13 [486]	Y	250 lbs.
LPTR4-3019	30 U	28 U	4	19.68 [500]	38.70 [983]	19.00 [483]	55.15 [1401]	52.50 [1334]	19.13 [486]	Y	250 lbs.
LPTR4-1023	10 U	10 U	4	23.69 [602]	46.67 [1185]	23.00 [584]	20.15 [512]	17.50 [445]	19.13 [486]	---	200 lbs.
LPTR4-1223	12 U	12 U	4	23.69 [602]	46.67 [1185]	23.00 [584]	23.65 [601]	21.00 [533]	19.13 [486]	---	200 lbs.
LPTR4-1423	14 U	12 U	4	23.69 [602]	46.67 [1185]	23.00 [584]	27.15 [690]	24.50 [622]	19.13 [486]	---	200 lbs.
LPTR4-1623	16 U	14 U	4	23.69 [602]	46.67 [1185]	23.00 [584]	30.65 [779]	28.00 [711]	19.13 [486]	---	200 lbs.
LPTR4-2123	21 U	18 U	4	23.69 [602]	46.67 [1185]	23.00 [584]	39.40 [1001]	36.75 [933]	19.13 [486]	---	200 lbs.
LPTR4-2423	24 U	23 U	4	23.69 [602]	46.67 [1185]	23.00 [584]	44.65 [1134]	42.00 [1067]	19.13 [486]	Y	200 lbs.
LPTR4-2823	28 U	24 U	4	23.69 [602]	46.67 [1185]	23.00 [584]	51.65 [1312]	49.00 [1245]	19.13 [486]	Y	200 lbs.
LPTR4-3023	30 U	28 U	4	23.69 [602]	46.67 [1185]	23.00 [584]	55.15 [1401]	52.50 [1334]	19.13 [486]	Y	200 lbs.

Rack dimensions (rounded) – inches and [mm]; 1U = 1.75"

THIS SPEC

**BASIC OPERATION:** Rack pictured may depict a different size than spec sheet.

**DOCKING:**  
Rack can be removed from base for offsite integration.

**OPERATING:**  
**Slide Out:** Grasp two front rails and pull rack firmly towards you, sliding it along rails in base. Rack locks in place when fully forward (0 degrees).  
**Rotate:** Press center button to release turntable and rotate rack left or right. Rack locks in place at 60 and 90 degrees.  
**Slide In:** With rack rotated back to 0 degrees, depress right tab to release lock and slide rack back into base.

**WIRING:**  
Ensure adequate slack is allowed for rotation by performing wire tie-offs with rack in fully rotated position (90 degrees).

**SECURING:**  
After wiring, attach front finishing panel with screws to secure rack in rolled-back position. *Note: Use screws to secure rack even if front finishing panel is not utilized.*

# TECHNICAL DRAWINGS

Dimensions are inches and [mm] unless stated otherwise.

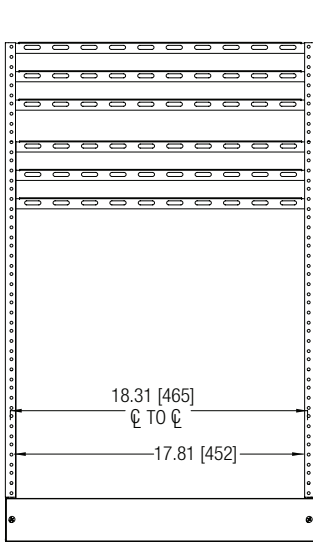

**FRONT VIEW**

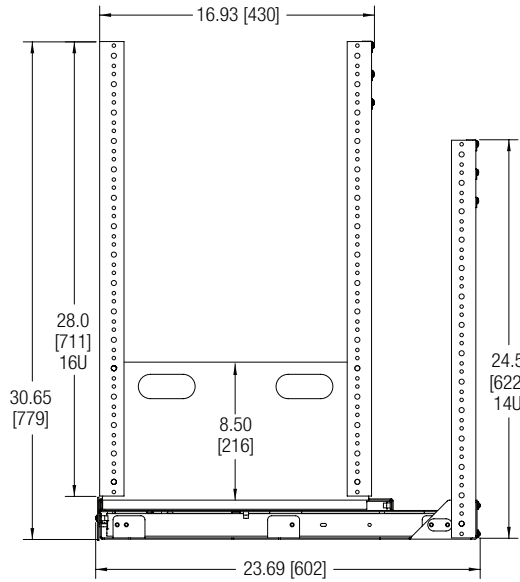

**SIDE VIEW**

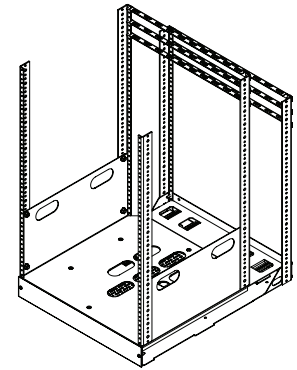

**ISO VIEW**

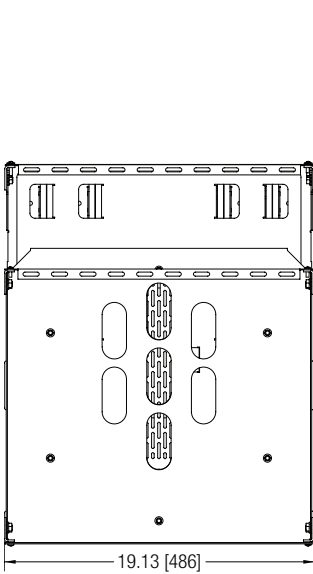

**BASE - TOP VIEW  
(RETRACTED / DOCKED)**

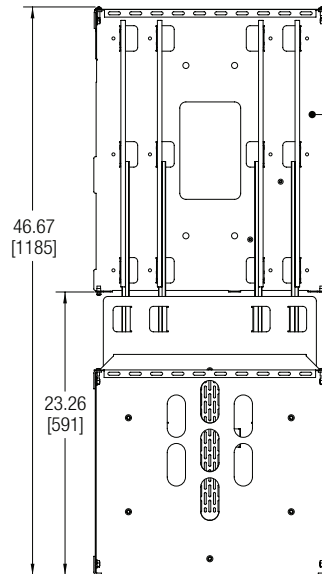

**BASE - TOP VIEW  
(EXPANDED / PULLED OUT)**

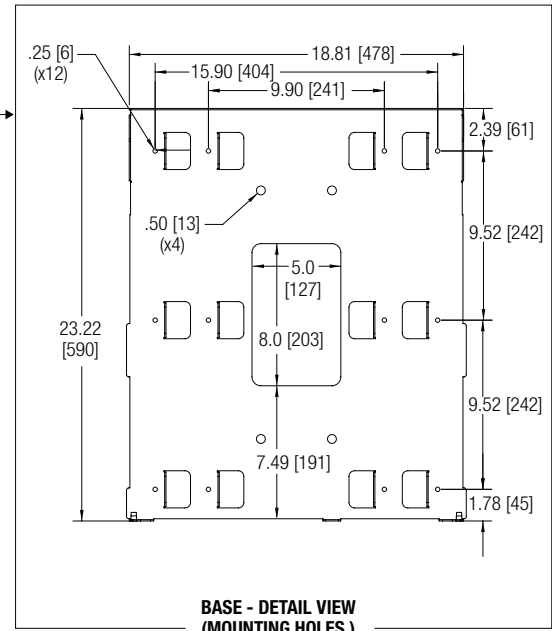

**BASE - DETAIL VIEW  
(MOUNTING HOLES)**