

A tile-bridge distributes the weight of a speaker assembly to the ceiling support structure in a suspended 2' x 2' or 2' x 4' tile ceiling, reducing the likelihood of tiles sagging under the weight of the speaker, and helping to maintain the overall aesthetics of the installation. Tile-bridges are often required by local building codes for safety purposes. The LBS8-CP requires a backbox.

*Note that speaker installation should always be performed according to all local building codes and regulations, many of which require a backbox.*

### FEATURES:

- **Construction:** Formed 22-gauge galvanized steel construction for lightweight, rigid support. The T-bridge features multiple attachment points for versatility.
- **Overall Dimensions:** 23.75" x 16.25" (12" diameter opening)
- **Origin:** Made in the U.S.A.
- **Installation:**
  - **Compatibility:** The tile-bridge mounts a standard 8" speaker assembly with a screw-mount grille and backbox. See page two for a list of compatible components.
  - **Seismic Anchoring:** Two wire-tie points for seismic anchoring where required by code.
  - **Standard Installation:** Backboxes are mounted to the tile-bridge using four 8-32 bolts (not included).
- **A&E Specifications:** The tile bridge shall be Lowell model LBS8-CP, which shall be formed 22-gauge galvanized steel construction engineered to distribute the weight of an 8" speaker assembly to the ceiling support system in a 2' x 2' or 2' x 4' suspended ceiling. The tile bridge shall include two wire-tie points for seismic anchoring where required by code.

### LBS Series (Tile Bridge) Summary

Model No.	For Speaker Size	For Grille Type	Backbox*	Dimensions	Opening	Material
LBS4-DX	4"	screw or torsion	required	23.75" x 12.13"	6.38" diameter	galvanized steel
LBS4-R	4"	screw	infinite baffle only**	23.75" x 12.13"	5.19" diameter	galvanized steel
LBS8	8"	screw	optional	23.75" x 15.50"	8.50" square	galvanized steel
<b>LBS8-CP</b>	<b>8"</b>	<b>screw</b>	<b>required</b>	<b>23.75" x 16.25"</b>	<b>12.00" diameter</b>	<b>galvanized steel</b>
LBS8-R1	8"	screw or torsion	required w/torsion grille	23.75" x 15.50"	10.75" diameter	galvanized steel

\* Check and follow all local building codes for backbox requirements.

\*\* The tile-bridge will not accept a backbox.

This spec



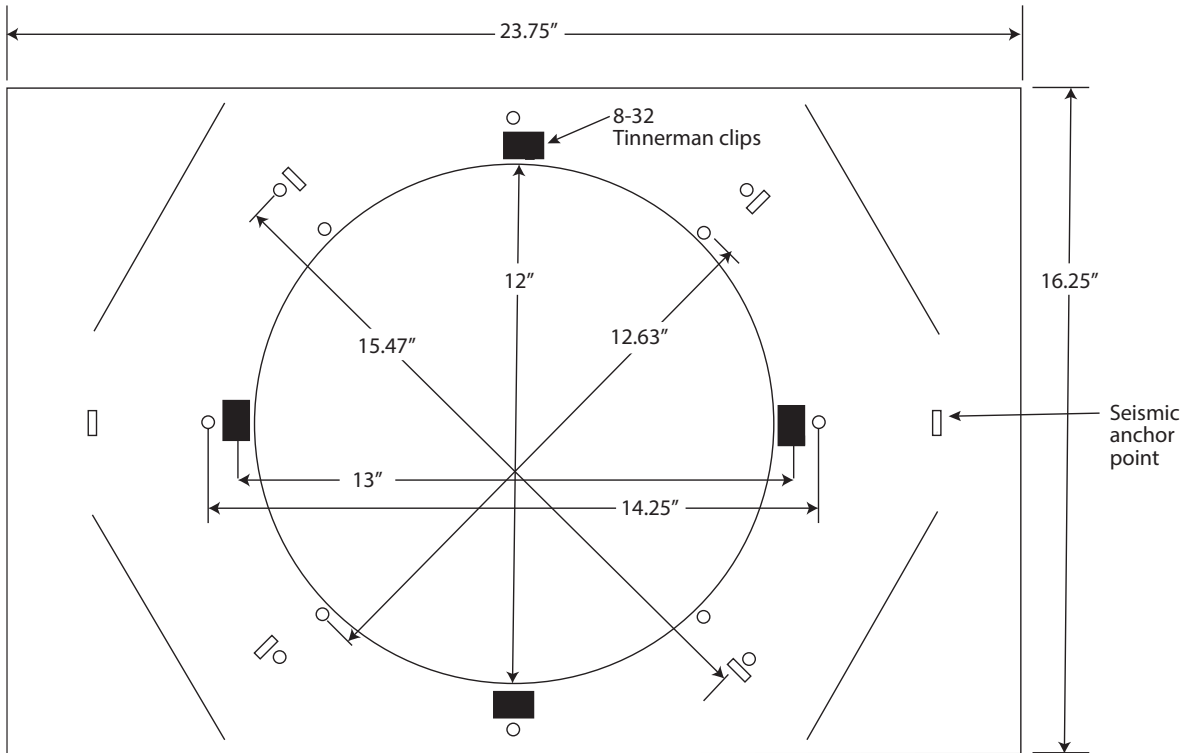

**COMPATIBLE COMPONENTS:** (order separately)

<i>Screw-mount Grille</i>	<i>Backbox (required)</i>	<i>Tile-Bridge *</i>
A8-AW, CS-8H, L08-P, RS8-AW, WB-8	CP84, CP87, CP810, DX108	LBS8-CP

\* The tile-bridge does not include mounting bolts. The installer will need to supply four (4) 8-32 bolts to mount the tile-bridge to a backbox.

