

Model No.

LT2-810-BB

Lay-in Tile Ceiling Loudspeaker

INCLUDES:

- 8-inch 15W dual cone driver
- 2x2 grille with subplate
- 0.147 cu.ft. enclosure

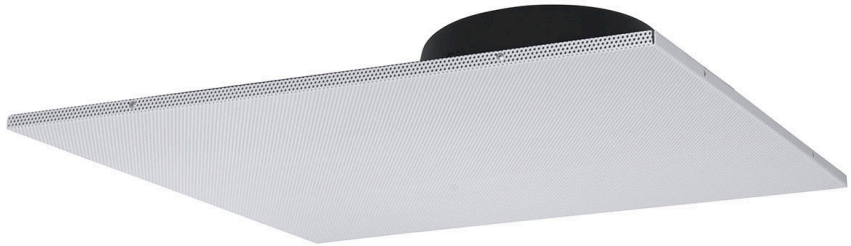

LT SERIES SPEAKERS are pro systems made for quick installation in suspended lay-in tile ceilings. The 2x2 assembly replaces a 2x2 ceiling tile. This model features an 8-inch 15W dual cone driver, 2x2 white grille with black subplate and 0.147 cu.ft. enclosure.

FEATURES

PERFORMANCE: This model is ideal for applications providing commercial paging and/or background music.

DRIVER (810): The 8-inch 15W dual cone driver with 10 oz. magnet provides a step up in full range performance from the commercial industry standard, delivering solid performance and value for paging and/or background music applications that require clear communications.

- Driver magnet: 10 oz. ceramic, 3/4-inch hard fiber whizzer cone, 1-inch voice coil, 20-gauge steel frame with zinc-plated finish
- Driver weight: 2.0 lbs.
- Driver depth: 2.84 in.

GRILLE WITH SUBPLATE (2X2): Fine-perforation steel grille with white powder epoxy finish is designed to provide maximum free-air space for excellent sound transmission, while maintaining an unobtrusive appearance in new or existing lay-in tile ceilings. Includes black subplate and four restraint tabs for code compliance.

- The 2x2 (23.75-in. x 23.75-in.) grille assembly replaces a 2x2 ceiling tile.

ENCLOSURE (8XD4): Certified U.S. steel enclosure with black powder epoxy finish.

- Volume: 0.147 cu.ft.
- Polyurethane foam disc
- Enclosure is offset on the 23.75-in. x 23.75-in. grille assembly to accommodate above-ceiling obstructions.

INSTALLATION:

- Assembly Dimensions: 23.75-in.L x 23.75-in.W x 4.5-in.H
- Restraint Tabs: The assembly features four restraint tabs for code compliance tie-offs.
- Connections: Driver leads exit enclosure through a metal clamp for fast connections — just splice connecting wires, push inside the enclosure, and tighten clamp.

COMPLIANCE & CERTIFICATIONS:

- Made in the U.S.A. with certified U.S. steel and global components.

FEATURES



TECHNICAL DRAWINGS

Dimensions are provided in inches.

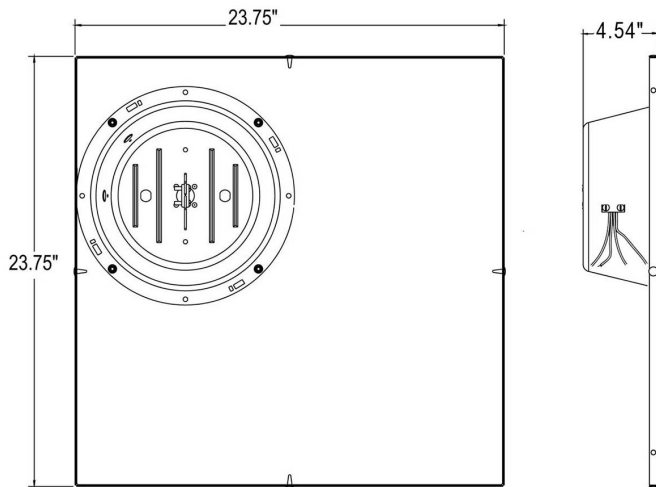

DRIVER SPECIFICATIONS

Driver No.	Size	Power Rating	Type	Ceramic Magnet	Frequency Response	Dispersion @ 2000Hz(-6dB)	Voice Coil Impedance	Voice Coil Diameter	Sensitivity 1W/1M	Max SPL*	Driver Depth	Driver Weight
810	8 in.	15W	dual cone	10 oz.	54Hz-11.6kHz (±6dB) 50Hz-20kHz (±6.6dB)	95 degrees conical	8 ohms	1 in.	97.9dB avg.	109.7dB	2.84 in.	2.0 lbs.

*Calculated value 1M @ driver power rating. See spec sheet for driver 810 for additional information.

TEST METHODOLOGIES: Lowell speaker systems are thoroughly tested to provide specifiers and contractors with accurate data. Test equipment includes the Gold-Line TEF-20 analyzer.

- **POWER HANDLING:** specification is based on E.I.A. Standard RS-426B.
- **FREQUENCY RESPONSE:** describes the usable response range defined by a ± 6dB window, which is useful in predictive engineering calculations.
- **SENSITIVITY:** is a computer calculation of the log average sound pressure level (SPL) over the entire engineering bandwidth as given in the Frequency Response (± 6dB).
- **MAXIMUM SPL:** is calculated based on the Power Handling and the measured log average Sensitivity where Maximum SPL = (Sensitivity @ 1W/1M) + 10 log (Power Handling).
- **DISPERSION ANGLE:** is defined as the angle of coverage that is no more than 6dB down from the on-axis value averaged over the 2kHz octave band. Since speech intelligibility is dependent upon the 2kHz octave, this specification is useful in designing voice reinforcement and music systems that provide even coverage and intelligibility. The polar plots illustrate how the system performs when hung in free space (360°) or half-space (180°) in the case of a recessed speaker.

A&E SPECIFICATIONS:

The loudspeaker for suspended lay-in tile ceilings shall be Lowell Model LT2-810-BB. The 2x2 system shall directly replace a 2x2 ceiling tile. Each assembly shall include a factory-mounted driver mounted to a 2x2 subplate and fine perforation steel grille with white powder epoxy finish. The driver shall be 8-inch dual cone with 15W power rating. It shall have a magnet weight of 10 ozs., frequency response of 54Hz-11.6kHz (±6dB); 50Hz-20kHz (±6.6dB) and average sensitivity of 97.9dB measured 1W/1M. The system shall include a steel backbox (.147 cu.ft. volume) with leads exiting through a metal clamp. The assembly shall be made in the U.S.A. with global components.

LT / LT2 SERIES OVERVIEW

Model No.	Driver	Transformer	Taps	Enclosure	Grille	Volume Control	Listed	Driver Specs (measured half space)		
								Sensitivity*	Frequency Response	Dispersion**
LT-410-72-BB	4" 15W single cone	25V / 70V	.25, .5, 1, 2, 5W	.147 cu.ft.	1 x 2	---	---	90.8 dB	67Hz-16kHz (±6dB) 53Hz-20kHz (±8dB)	170°
LT-810	8" 15W dual cone	---	---	---	1 x 2	---	---	97.9 dB	54Hz-11.6kHz (±6dB) 50Hz-20kHz (±6.6dB)	95°
LT-810-72	8" 15W dual cone	25V / 70V	.25, .5, 1, 2, 5W	---	1 x 2	---	---	97.9 dB	54Hz-11.6kHz (±6dB) 50Hz-20kHz (±6.6dB)	95°
LT-810-BB	8" 15W dual cone	---	---	.147 cu.ft.	1 x 2	---	---	97.9 dB	54Hz-11.6kHz (±6dB) 50Hz-20kHz (±6.6dB)	95°
LT-810-425-BB	8" 15W dual cone	25V	.5, 1, 2, 4W	.147 cu.ft.	1 x 2	---	---	97.9 dB	54Hz-11.6kHz (±6dB) 50Hz-20kHz (±6.6dB)	95°
LT-810-72-BB	8" 15W dual cone	25V / 70V	.25, .5, 1, 2, 5W	.147 cu.ft.	1 x 2	---	---	97.9 dB	54Hz-11.6kHz (±6dB) 50Hz-20kHz (±6.6dB)	95°
LT-810-72-BB-VC	8" 15W dual cone	25V / 70V	.25, .5, 1, 2, 5W	.147 cu.ft.	1 x 2	Knob	---	97.9 dB	54Hz-11.6kHz (±6dB) 50Hz-20kHz (±6.6dB)	95°
THIS SPEC  LT2-810-BB	8" 15W dual cone	---	---	.147 cu.ft.	2 x 2	---	---	97.9 dB	54Hz-11.6kHz (±6dB) 50Hz-20kHz (±6.6dB)	95°
LT2-810-425-BB	8" 15W dual cone	25V	.5, 1, 2, 4W	.147 cu.ft.	2 x 2	---	---	97.9 dB	54Hz-11.6kHz (±6dB) 50Hz-20kHz (±6.6dB)	95°
LT2-810-72-BB	8" 15W dual cone	25V / 70V	.25, .5, 1, 2, 5W	.147 cu.ft.	2 x 2	---	---	97.9 dB	54Hz-11.6kHz (±6dB) 50Hz-20kHz (±6.6dB)	95°
LT2-810-72-BB-VC	8" 15W dual cone	25V / 70V	.25, .5, 1, 2, 5W	.147 cu.ft.	2 x 2	Knob	---	97.9 dB	54Hz-11.6kHz (±6dB) 50Hz-20kHz (±6.6dB)	95°
LT-830-BB	8" 20W coaxial	---	---	.147 cu.ft.	1 x 2	---	---	97.0 dB	57Hz-14kHz (±6dB) 44Hz-20kHz (±7.6dB)	80°
LT-830-870-BB	8" 20W coaxial	70V	1, 2, 4, 8W	.147 cu.ft.	1 x 2	---	---	97.0 dB	57Hz-14kHz (±6dB) 44Hz-20kHz (±7.6dB)	80°
LT2-830-T870-VB	8" 20W coaxial	70V	1, 2, 4, 8W	.8 cu.ft.	2 x 2	---	---	97.0 dB	57Hz-14kHz (±6dB) 44Hz-20kHz (±7.6dB)	80°
LT2-830-TM16-VB	8" 20W coaxial	70V	4, 8, 16W	.8 cu.ft.	2 x 2	---	---	97.0 dB	57Hz-14kHz (±6dB) 44Hz-20kHz (±7.6dB)	80°
LT-8A-VB	8" 50W coaxial	---	---	.8 cu.ft.	1 x 2	---	UL	90.6 dB	40Hz-19.4kHz (±6dB) 40Hz-20kHz (±7.3dB)	90°
LT-8A-T870-VB	8" 50W coaxial	70V	1.1, 2, 4, 8W	.8 cu.ft.	1 x 2	---	UL	90.6 dB	40Hz-19.4kHz (±6dB) 40Hz-20kHz (±7.3dB)	90°
LT2-8A-VB	8" 50W coaxial	---	---	.8 cu.ft.	2 x 2	---	UL	90.6 dB	40Hz-19.4kHz (±6dB) 40Hz-20kHz (±7.3dB)	90°
LT2-8A-T870-VB	8" 50W coaxial	70V	1.1, 2, 4, 8W	.8 cu.ft.	2 x 2	---	UL	90.6 dB	40Hz-19.4kHz (±6dB) 40Hz-20kHz (±7.3dB)	90°
LT2-8A-TM32-VB	8" 50W coaxial	70V	8, 16, 32W	.8 cu.ft.	2 x 2	---	---	90.6 dB	40Hz-19.4kHz (±6dB) 40Hz-20kHz (±7.3dB)	90°

* Average SPL @ 1W/1M

** Conical @ 2kHz octave (-6dB)