



Model No.

LGVR-4436

Gangable Video Rack (22"W)

Panel Space:	44U or 77.00" [1956 mm]
Overall Height:	83.125" [2111 mm]
Overall Depth:	36.00" [914 mm]
Overall Width:	22.00" [559 mm]
Load Capacity:	3150 lbs. [1429 kg] (UL Listed)



FULLY WELDED GANGABLE VIDEO RACK with adjustable rails. Certified U.S. steel, 16-gauge frame with seamless side frame construction, 14-ga. top, and 14-ga. bottom reinforced at load-bearing junctions for robust support, strength equivalent to 11-ga. steel. Durable black wrinkle powder epoxy finish.

FEATURES

FRONT: Frame nutserts are ready to add optional surface-mount door (left or right swing). Order front door separately.

REAR: Knockout panel in frame above and below door. Combination KOs for conduit (1/2"-3/4", 1/2"-1", 3/4"-1", 1"-1-1/2" and 1"-2") and KOs for wireless antennae (1/2"). Standard model includes recessed rear door with key lock (left or right swing).

SIDES (open access): Each side features lacing bars for quick tie-n-slide lacing of video cable bundles, plus 4" x 1.5" obround openings along base for cabling between racks. Optional side panel increases overall width 1" per side.

CONFIGURABLE TOP: 15U opening features riveted 10-32 threaded rails on 19" EIA spacing.

BOTTOM (open access): Includes 10-32 threaded grounding stud in corner, 3/8"-16 threaded T-nuts for (optional) leg levelers, and holes for anchor bolts (by others). Opening is 21.88"D x 18.89"W.

RAILS (fully adjustable): Two pairs of 11-ga. steel 10-32 threaded rails on EIA spacing with numbered RU increments (rails mount in either direction). Black finish. Clearance for wire management from front rail to outside frame (1.5") and from front rail to (optional) surface-mount door (2.25").

HARDWARE: Black pilot point screws with captive washers for quick installation. (50)

COMPLIANCE: EIA/TIA compliant. RoHS compliant. UL 2416 Listed in USA and Canada.

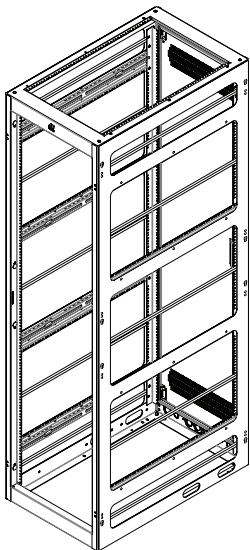

A&E SPECIFICATIONS:

The EIA/TIA compliant 19" gangable equipment rack shall be Lowell model LGVR-4436 with overall dimensions of 83.125"H x 36.00"D x 22.00"W; usable height of 44 rack units, and usable depth of 33.34". Rack construction shall be fully welded certified U.S. steel with 16-gauge frame, 14-ga. top, and 14-ga. bottom reinforced at load-bearing junctions, all with black wrinkle powder epoxy finish. Open sides shall feature lacing bars and obround openings along bottom. The rack shall include a recessed rear door with key lock, combination knockouts for conduit wiring above and below door (1/2"-3/4", 1/2"-1", 3/4"-1", 1"-1-1/2" and 1"-2" KOs), and knockouts for wireless antennae (1/2" KOs). The front shall feature provisions to accept an (optional) surface-mount door with left or right hand swing. The top shall feature a 15U opening with riveted 10-32 threaded rails on 19" EIA spacing. Rack bottom shall have an opening measuring 31.88" x 18.89" and include a grounding stud. Rack shall include 2 pairs of adjustable 11-gauge steel rails tapped 10-32 on 19" EIA spacing with black finish and numbered rack unit increments. The UL 2416 Listed rack shall be manufactured in the U.S.A. with a UL Listed load capacity of 3150 lbs.

LGVR SERIES SUMMARY

Model No.	Rack Units	Overall Depth	Usable Depth	Overall Height	Usable Height	Overall Width	Top Opening	Bottom Opening Depth	Bottom Opening Width	Adj. Rails
LGVR-4432	44 U	32.00 [813]	29.34 [745]	83.13 [2111]	77.00 [1956]	22.00 [559]	15 U	27.88 [708]	18.89 [480]	2 pr
LGVR-4436	44 U	36.00 [914]	33.34 [847]	83.13 [2111]	77.00 [1956]	22.00 [559]	17 U	31.88 [810]	18.89 [480]	2 pr

Rack dimensions (rounded) – inches and [mm]; 1U = 1.75"

THIS SPEC

TECHNICAL DRAWINGS

Dimensions are inches and [mm] unless stated otherwise.

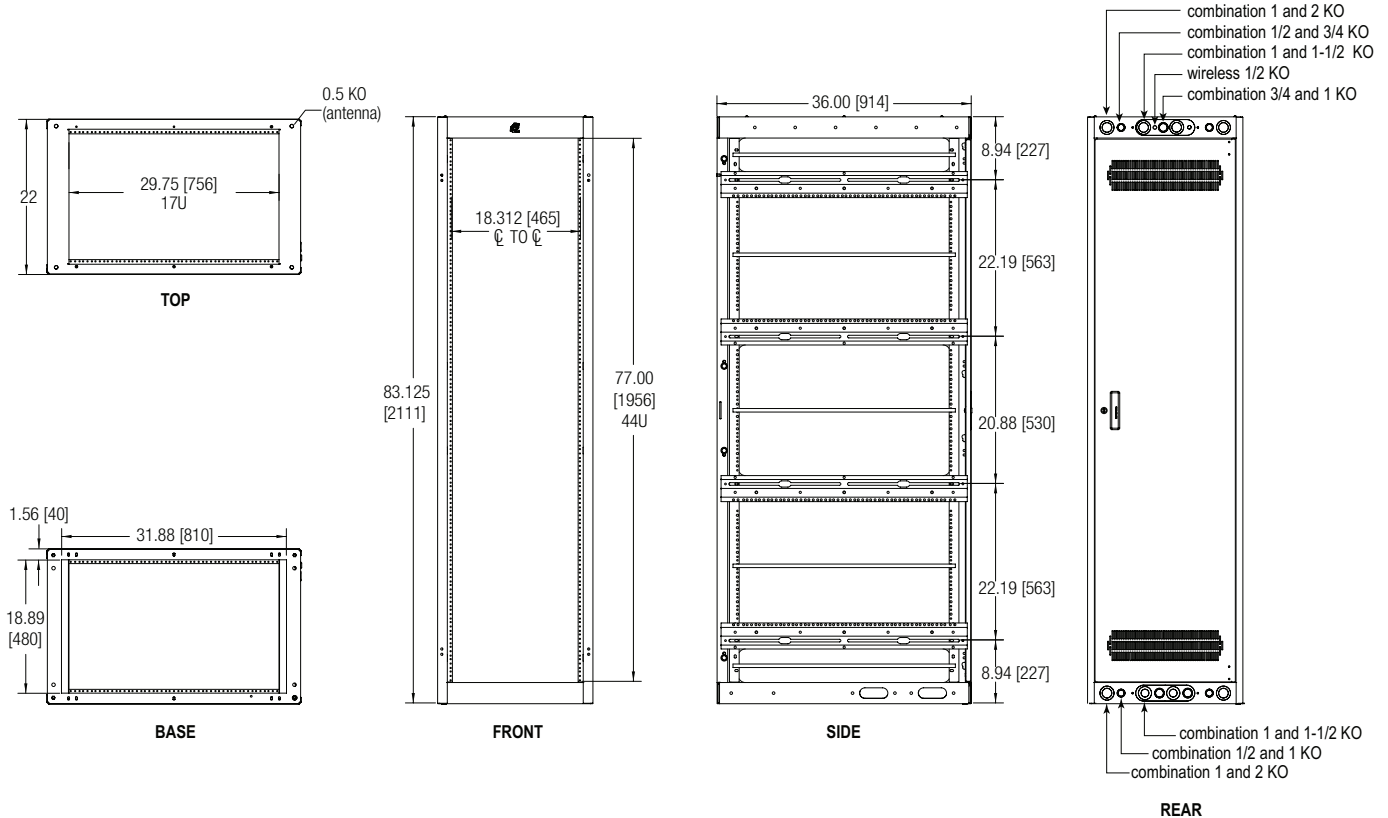

OPTIONAL

- Solid steel surface-mount front door with key lock model LFD-44.
- Smoked plexiglass surface-mount front door with key lock model LFD-44P.
- Fully-vented surface-mount front door with key lock model LFD-44FV.
- 1-pr. solid side panels model SDP-4436.
- Fully-vented rear door with key lock model LRD-44FV.
- Mobile base model LMNB-36, which shall add 1.25" to height.
- Additional pair of 44U mounting rails model RRN-44.
- Set of four leg levelers model LL.
- Ganging hardware model RGH-40.