

Model No.

# 10LVC

Volume Control

INCLUDES:

- 10W attenuator
- 1-gang standard wall plate
- Fluted rotary knob

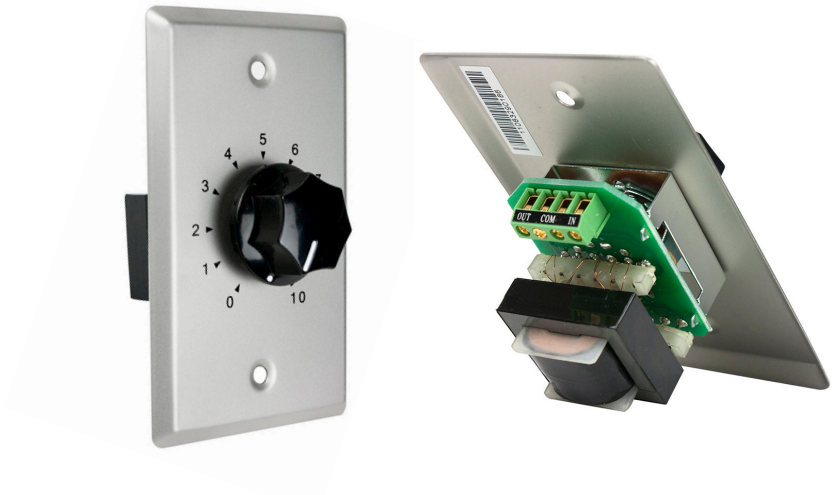

---

10W ATTENUATOR provides precise level adjustment of single or multiple speaker lines. This unit includes a standard one-gang stainless steel wall plate with black rotary knob.

---

## FEATURES

DESCRIPTION: Mono autoformer attenuator for use with 25V/70V/100V speaker line

POWER RATING: 10W

ATTENUATION: 3dB per step (33dB total with two steps of 6dB each before off)

TERMINATION: Phoenix style plug-in screw termination strips for pre-wire convenience

WIRE CAPACITY: Up to 14-gauge

SWITCH TYPE: Fluted rotary knob, black

SWITCH POSITIONS: 0-10

WALL PLATE: One-gang standard wall plate, stainless steel.

INSTALLATION: Designed to fit a one-gang E.O. box with minimum inside dimensions of 1.875-in.W x 2.688-in.H x 2.125-in.D (not included)

COUNTRY OF ORIGIN: China

## A&E SPECIFICATIONS

The mono autoformer attenuator volume control shall be Lowell model 10LVC, which shall have a 10W power rating and attenuation of 3dB per step with two steps of 6dB each before off. The volume control shall include a standard one-gang stainless steel wall plate with printed scale and black rotary knob. The unit shall be able to mount in an E.O. box with minimum inside dimensions of 1.875-in. x 2.688-in. x 2.125-in.

# DRAWINGS

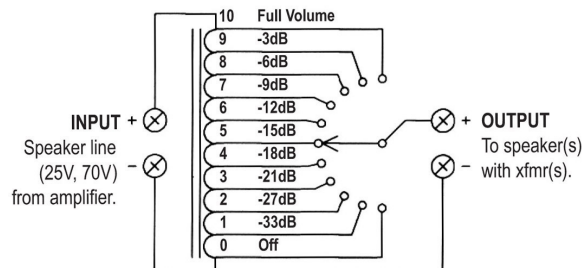
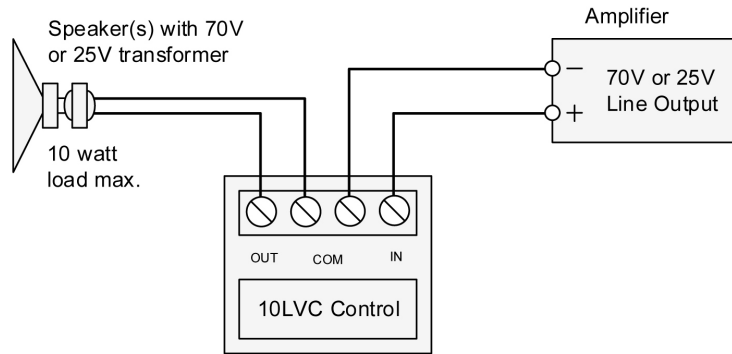
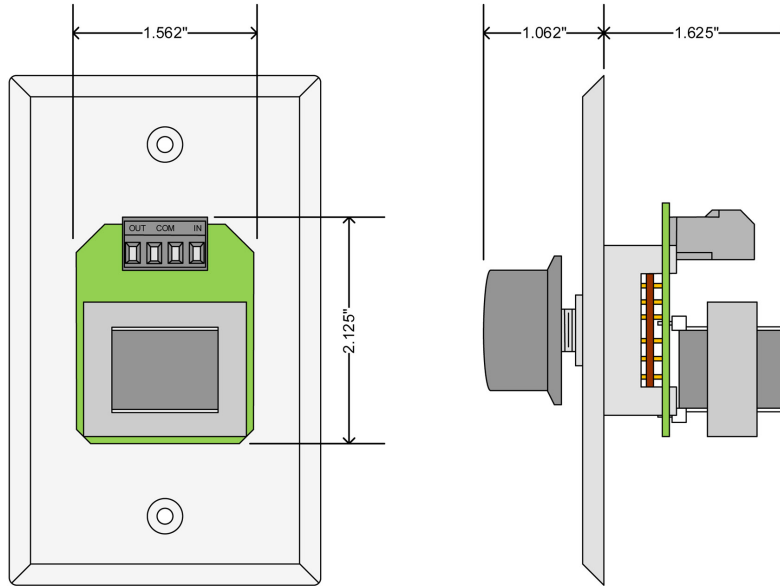

## OVERVIEW: MONO ATTENUATORS

THIS SPEC

Model No.	Power Rating	Attenuation Steps/Total *	VC Type	Priority Relay	Mount Type **	Plate Size	Color	Switch	Listing	For Use With speaker line	TAA Compliant
10LVC	10 W	3dB/33dB	autoformer	---	standard wall plate	1-gang	ss	knob	----	25V/70V	no
25LVC	25 W	3dB/33dB	autoformer	---	standard wall plate	1-gang	ss	knob	ETL	25V/70V	yes
25LVC-SW	25 W	3dB/33dB	autoformer	---	standard wall plate	1-gang	white	knob	ETL	25V/70V	yes
25LVC-DB	25 W	3dB/33dB	autoformer	---	decorator wall plate	1-gang	black	knob	ETL	25V/70V	yes
25LVC-DW	25 W	3dB/33dB	autoformer	---	decorator wall plate	1-gang	white	knob	ETL	25V/70V	yes
25LVC-RM	25 W	3dB/33dB	autoformer	---	adhesive label	---	black	knob	ETL	25V/70V	yes
50LVC	50 W	3dB/33dB	autoformer	---	standard wall plate	1-gang	ss	knob	ETL	25V/70V	yes
50LVC-DB	50 W	3dB/33dB	autoformer	---	decorator wall plate	1-gang	black	knob	ETL	25V/70V	yes
50LVC-DW	50 W	3dB/33dB	autoformer	---	decorator wall plate	1-gang	white	knob	ETL	25V/70V	yes
50LVC-RM	50 W	3dB/33dB	autoformer	---	adhesive label	---	black	knob	ETL	25V/70V	yes
100LVC	100 W	3dB/33dB	autoformer	---	standard wall plate	1-gang	ss	knob	ETL	25V/70V	yes
100LVC-DB	100 W	3dB/33dB	autoformer	---	decorator wall plate	1-gang	black	knob	ETL	25V/70V	yes
100LVC-DW	100 W	3dB/33dB	autoformer	---	decorator wall plate	1-gang	white	knob	ETL	25V/70V	yes
100LVC-DSB	100 W	3dB/33dB	autoformer	---	decorator wall plate	1-gang	ss / black	knob	ETL	25V/70V	yes
100LVC-RM	100 W	3dB/33dB	autoformer	---	adhesive label	---	black	knob	ETL	25V/70V	yes
10015LVC	100 W	1.5dB/13.5dB	autoformer	---	standard wall plate	1-gang	ss	knob	ETL	25V/70V	yes
10015LVC-DB	100 W	1.5dB/13.5dB	autoformer	---	decorator wall plate	1-gang	black	knob	ETL	25V/70V	yes
10015LVC-DW	100 W	1.5dB/13.5dB	autoformer	---	decorator wall plate	1-gang	white	knob	ETL	25V/70V	yes
10015LVC-RM	100 W	1.5dB/13.5dB	autoformer	---	adhesive label	---	black	knob	ETL	25V/70V	yes
100LVC-PA	100 W	3dB/33dB	autoformer	yes	standard wall plate	1-gang	ss	knob	ETL	25V/70V	yes
100LVC-PA-DB	100 W	3dB/33dB	autoformer	yes	decorator wall plate	1-gang	black	knob	ETL	25V/70V	yes
100LVC-PA-DW	100 W	3dB/33dB	autoformer	yes	decorator wall plate	1-gang	white	knob	ETL	25V/70V	yes
100LVC-PA-RM	100 W	3dB/33dB	autoformer	yes	adhesive label	---	black	knob	ETL	25V/70V	yes
KL100-DW	100 W	3dB/33dB	autoformer	---	decorator wall plate	1-gang	white	key	ETL	25V/70V	yes
KL100-DSB	100 W	3dB/33dB	autoformer	---	decorator wall plate	1-gang	ss / black	key	ETL	25V/70V	yes
200LVC	200 W	3dB/33dB	autoformer	---	standard wall plate	2-gang	ss	knob	ETL	70V	yes
200LVC-DSB	200 W	3dB/33dB	autoformer	---	decorator wall plate	2-gang	ss / black	knob	ETL	70V	yes
200LVC-RM	200 W	3dB/33dB	autoformer	---	adhesive label	---	black	knob	ETL	70V	yes
200LVC-RMDB	200 W	3dB/33dB	autoformer	---	subplate	---	black	knob	ETL	70V	yes
KL100-PA-DSB	100 W	3dB/33dB	autoformer	yes	decorator wall plate	1-gang	ss / black	key	ETL	70V	yes
KL100-PA-DSW	100 W	3dB/33dB	autoformer	yes	decorator wall plate	1-gang	ss / white	key	ETL	70V	yes
KL200-DSB	200W	3dB/33dB	autoformer	---	decorator wall plate	2-gang	ss / black	key	ETL	70V	yes
SVC100-PA-DW	100W	3dB/33dB	autoformer	yes	decorator wall plate	1-gang	white	slide-bar	ETL	70V	yes

\* Note: Models with 33dB total have 2 steps of 6dB each before off. Models with 13.5dB total have 2 steps with 3dB each before off.

\*\* Adhesive labels are used in rackmount panels or custom applications. ss = stainless steel