

features.

- **Panel Space:** 8U or 14.00 [356]
- **Overall Height:** 15.86" [403]
- **Overall Depth:** 11.50" [292]
- **Overall Width:** 19.06" [484]
- **Description:** Lightweight two-post stand with angled mounting rails has a small footprint with just enough rack space for small AV or IT equipment arrangements, ideal where space is limited and a full size rack is not needed. Compact design is suitable for installation on or under a desk for convenient access to mounted electronics, such as a recording front end or post production equipment, or multiple effects processors. Ships unassembled.
- **Hardware:** Includes assembly hardware and rubber feet to protect desk surface.
- **Compliance:** EIA/TIA compliant. RoHS compliant.
- **Load Capacity:** 80 lbs. [36kg]
- **Construction:** 16-gauge certified U.S. steel side supports and front panel. 11-gauge post rails. Smooth black powder epoxy finish.
- **Installation:** Use freestanding or bolted to a desk or counter.
- **Mounting Rails:** 11-gauge steel integral (8U) post rails tapped 10-32 with numbered RU increments. Rails are angled 10 degrees for easy viewing of equipment controls from a seated position.

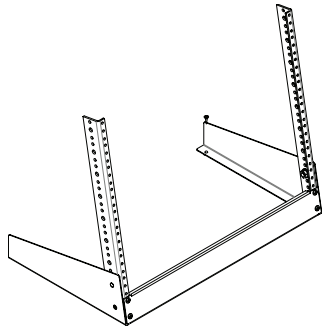

a&e specifications.

The EIA/TIA compliant, two post rack stand shall be Lowell model #LRS-8 with overall dimensions of 15.86"H x 11.50"D x 19.06"W and usable height of 8 rack units on a 10 degree angle. Rack construction shall be certified U.S. steel—16-gauge side supports and front panel, and 11-gauge post rails tapped 10-32—all with smooth black powder epoxy finish. The rack shall support a load capacity of 80 lbs. It shall be manufactured in the U.S.A. and ship unassembled.

LRS series summary

Model No.	Panel Space	Overall Depth	Overall Height	Usable Height	Overall Width	(Angled) Post Mounting Rails	Load Capacity
▶ LRS-8	8 U	11.50 [292]	15.86 [403]	14.00 [356]	19.06 [484]	2	80 lbs. [36kg]
LRS-12	12 U	11.50 [292]	22.86 [581]	21.00 [533]	19.06 [484]	2	80 lbs. [36kg]

Rack dimensions (rounded) – inches and [mm]; 1U = 1.75"

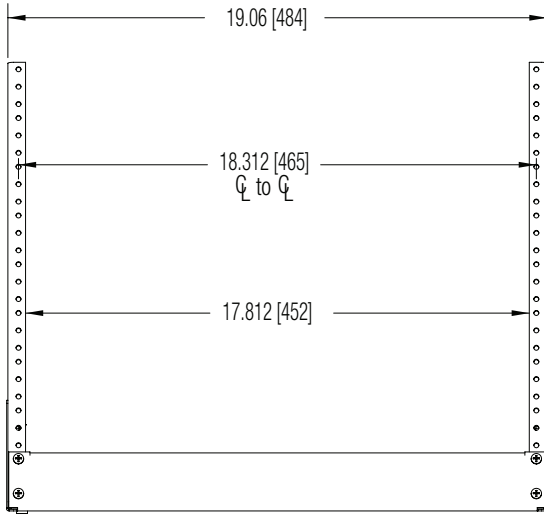

FRONT VIEW

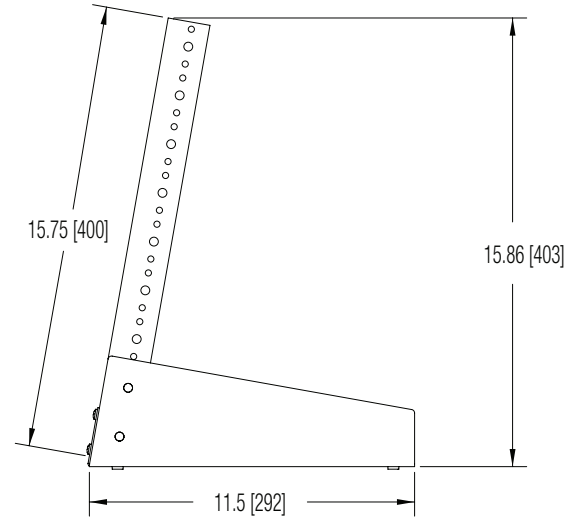

SIDE VIEW