

Model No.

LT-810

Lay-in Tile Ceiling Loudspeaker

INCLUDES:

- 8-inch 15W dual cone driver
- 1x2 grille with subplate



LT SERIES SPEAKERS are pro systems made for quick installation in suspended lay-in tile ceilings. This model features an 8-inch 15W dual cone driver, and 1x2 grille with subplate (no enclosure — infinite baffle). The patented* 1x2 assembly features an integral T-bar support that replaces one-half of a 2x2 or one-fourth of a 2x4 ceiling tile.

FEATURES

PERFORMANCE: This model is ideal for applications providing commercial paging and/or background music.

DRIVER (810): The 8-inch 15W dual cone driver with 10 oz. magnet provides a step up in full range performance from the commercial industry standard, delivering solid performance and value for paging and/or background music applications that require clear communications.

- Driver magnet: 10 oz. ceramic, 3/4-inch hard fiber whizzer cone, 1-inch voice coil, 20-gauge steel frame with zinc-plated finish
- Driver weight: 2.0 lbs.
- Driver depth: 2.84 in.

GRILLE WITH SUBPLATE (1X2): Fine-perforation steel grille with white powder epoxy finish is designed to provide maximum free-air space for excellent sound transmission, while maintaining an unobtrusive appearance in new or existing lay-in tile ceilings (non-regular, flush). Includes black subplate, restraint tab and hole for code compliance, and patented* integral T-bar to support the neighboring cut tile.

- The 1x2 (12.92-in. x 23.75-in.) grille/subplate assembly replaces one-half of a 2x2 or one-fourth of a 2x4 ceiling tile.

INSTALLATION:

- Assembly Dimensions: 23.75-in.L x 12.92-in.W x 3.7-in.H
- Patented* T-bar Support: Integral 2-foot T-bar attached to grille assembly supports the neighboring cut ceiling tile.
- Restraint Tab: The assembly features a restraint tab in one corner and a hole in the diagonally-opposite corner for code compliance tie-offs.

COMPLIANCE & CERTIFICATIONS:

- Made in the U.S.A. with certified U.S. steel and global components.

* U.S. patents 7,120,269; D467,579; 7,643,647

FEATURES



TECHNICAL DRAWINGS

Dimensions are provided in inches.

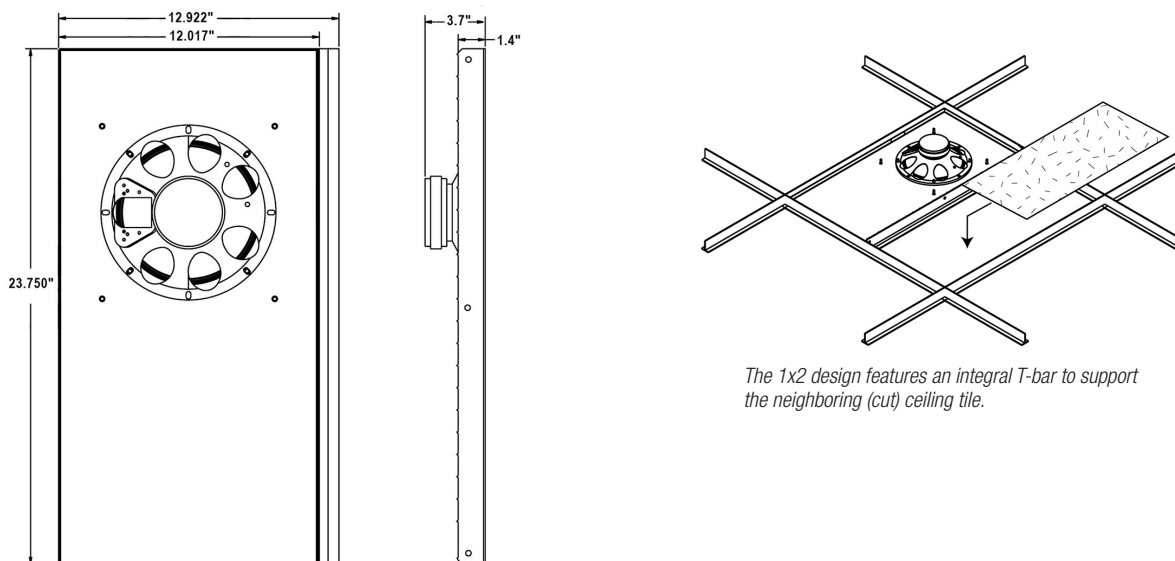

DRIVER SPECIFICATIONS

Driver No.	Size	Power Rating	Type	Ceramic Magnet	Frequency Response	Dispersion @ 2000Hz(-6dB)	Voice Coil Impedance	Voice Coil Diameter	Sensitivity 1W/1M	Max SPL*	Driver Depth	Driver Weight
810	8 in.	15W	dual cone	10 oz.	54Hz-11.6kHz (±6dB) 50Hz-20kHz (±6.6dB)	95 degrees conical	8 ohms	1 in.	97.9dB avg.	109.7dB	2.84 in.	2.0 lbs.

*Calculated value 1M @ driver power rating. See spec sheet for driver 810 for additional information.

TEST METHODOLOGIES: Lowell speaker systems are thoroughly tested to provide specifiers and contractors with accurate data. Test equipment includes the Gold-Line TEF-20 analyzer.

- **POWER HANDLING:** specification is based on E.I.A. Standard RS-426B.
- **FREQUENCY RESPONSE:** describes the usable response range defined by a ± 6dB window, which is useful in predictive engineering calculations.
- **SENSITIVITY:** is a computer calculation of the log average sound pressure level (SPL) over the entire engineering bandwidth as given in the Frequency Response (± 6dB).
- **MAXIMUM SPL:** is calculated based on the Power Handling and the measured log average Sensitivity where Maximum SPL = (Sensitivity @ 1W1M) + 10 log (Power Handling).
- **DISPERSION ANGLE:** is defined as the angle of coverage that is no more than 6dB down from the on-axis value averaged over the 2kHz octave band. Since speech intelligibility is dependent upon the 2kHz octave, this specification is useful in designing voice reinforcement and music systems that provide even coverage and intelligibility. The polar plots illustrate how the system performs when hung in free space (360°) or half-space (180°) in the case of a recessed speaker.

A&E SPECIFICATIONS

The loudspeaker for suspended lay-in tile ceilings (non-regular, flush) shall be Lowell Model No. LT-810. The 1x2 speaker assembly shall replace one-half of a 2x2 or one-fourth of a 2x4 ceiling tile and shall include an integral T-bar to support the adjacent cut ceiling tile. Each speaker shall include a factory-mounted driver mounted to a black subplate and fine perforation steel grille with white powder epoxy finish. The driver shall be 8-inch dual cone with 15W power rating and dispersion of 95 degrees conical. It shall have a magnet weight of 10 ozs., frequency response of 54Hz-11.6kHz (±6dB), 50Hz-20kHz (±6.6dB) and average sensitivity of 97.9dB measured 1W/1M. The assembly shall be made in the U.S.A. with global components.

LT / LT2 SERIES OVERVIEW

Model No.	Driver	Transformer	Taps	Enclosure	Grille	Volume Control	Listed	Driver Specs (measured half space)		
								Sensitivity*	Frequency Response	Dispersion**
LT-410-72-BB	4" 15W single cone	25V / 70V	.25, .5, 1, 2, 5W	.147 cu.ft.	1 x 2	---	---	90.8 dB	67Hz-16kHz (±6dB) 53Hz-20kHz (±8dB)	170°
THIS SPEC LT-810	8" 15W dual cone	---	---	---	1 x 2	---	---	97.9 dB	54Hz-11.6kHz (±6dB) 50Hz-20kHz (±6.6dB)	95°
LT-810-72	8" 15W dual cone	25V / 70V	.25, .5, 1, 2, 5W	---	1 x 2	---	---	97.9 dB	54Hz-11.6kHz (±6dB) 50Hz-20kHz (±6.6dB)	95°
LT-810-BB	8" 15W dual cone	---	---	.147 cu.ft.	1 x 2	---	---	97.9 dB	54Hz-11.6kHz (±6dB) 50Hz-20kHz (±6.6dB)	95°
LT-810-425-BB	8" 15W dual cone	25V	.5, 1, 2, 4W	.147 cu.ft.	1 x 2	---	---	97.9 dB	54Hz-11.6kHz (±6dB) 50Hz-20kHz (±6.6dB)	95°
LT-810-72-BB	8" 15W dual cone	25V / 70V	.25, .5, 1, 2, 5W	.147 cu.ft.	1 x 2	---	---	97.9 dB	54Hz-11.6kHz (±6dB) 50Hz-20kHz (±6.6dB)	95°
LT-810-72-BB-VC	8" 15W dual cone	25V / 70V	.25, .5, 1, 2, 5W	.147 cu.ft.	1 x 2	Knob	---	97.9 dB	54Hz-11.6kHz (±6dB) 50Hz-20kHz (±6.6dB)	95°
LT2-810-BB	8" 15W dual cone	---	---	.147 cu.ft.	2 x 2	---	---	97.9 dB	54Hz-11.6kHz (±6dB) 50Hz-20kHz (±6.6dB)	95°
LT2-810-425-BB	8" 15W dual cone	25V	.5, 1, 2, 4W	.147 cu.ft.	2 x 2	---	---	97.9 dB	54Hz-11.6kHz (±6dB) 50Hz-20kHz (±6.6dB)	95°
LT2-810-72-BB	8" 15W dual cone	25V / 70V	.25, .5, 1, 2, 5W	.147 cu.ft.	2 x 2	---	---	97.9 dB	54Hz-11.6kHz (±6dB) 50Hz-20kHz (±6.6dB)	95°
LT2-810-72-BB-VC	8" 15W dual cone	25V / 70V	.25, .5, 1, 2, 5W	.147 cu.ft.	2 x 2	Knob	---	97.9 dB	54Hz-11.6kHz (±6dB) 50Hz-20kHz (±6.6dB)	95°
LT-830-BB	8" 20W coaxial	---	---	.147 cu.ft.	1 x 2	---	---	97.0 dB	57Hz-14kHz (±6dB) 44Hz-20kHz (±7.6dB)	80°
LT-830-870-BB	8" 20W coaxial	70V	1, 2, 4, 8W	.147 cu.ft.	1 x 2	---	---	97.0 dB	57Hz-14kHz (±6dB) 44Hz-20kHz (±7.6dB)	80°
LT2-830-T870-VB	8" 20W coaxial	70V	1, 2, 4, 8W	.8 cu.ft.	2 x 2	---	---	97.0 dB	57Hz-14kHz (±6dB) 44Hz-20kHz (±7.6dB)	80°
LT2-830-TM16-VB	8" 20W coaxial	70V	4, 8, 16W	.8 cu.ft.	2 x 2	---	---	97.0 dB	57Hz-14kHz (±6dB) 44Hz-20kHz (±7.6dB)	80°
LT-8A-VB	8" 50W coaxial	---	---	.8 cu.ft.	1 x 2	---	UL	90.6 dB	40Hz-19.4kHz (±6dB) 40Hz-20kHz (±7.3dB)	90°
LT-8A-T870-VB	8" 50W coaxial	70V	1.1, 2, 4, 8W	.8 cu.ft.	1 x 2	---	UL	90.6 dB	40Hz-19.4kHz (±6dB) 40Hz-20kHz (±7.3dB)	90°
LT2-8A-VB	8" 50W coaxial	---	---	.8 cu.ft.	2 x 2	---	UL	90.6 dB	40Hz-19.4kHz (±6dB) 40Hz-20kHz (±7.3dB)	90°
LT2-8A-T870-VB	8" 50W coaxial	70V	1.1, 2, 4, 8W	.8 cu.ft.	2 x 2	---	UL	90.6 dB	40Hz-19.4kHz (±6dB) 40Hz-20kHz (±7.3dB)	90°
LT2-8A-TM32-VB	8" 50W coaxial	70V	8, 16, 32W	.8 cu.ft.	2 x 2	---	---	90.6 dB	40Hz-19.4kHz (±6dB) 40Hz-20kHz (±7.3dB)	90°

* Average SPL @ 1W/1M

** Conical @ 2kHz octave (-6dB)